

## DIGITAL BURNER CONTROLLER

DBC2000 SERIES

### PRODUCT HANDBOOK



#### APPLICATION

The Honeywell DBC2000 is a microprocessor-based integrated burner controller for automatically fired gas, oil or combination fuel industrial single burner power burner applications. The DBC2000 system consists of the relay module and wiring subbase. The DBC2000 Standard Model provides the minimum requirements to control an industrial burner system, such as automatic burner sequencing, flame supervision, system status indication, system or self-diagnostics and troubleshooting. The DBC2000 Enhanced Model includes an integrated Valve Proofing System, whilst the Ultimate model includes bus communication on top of this.

The DBC2000 is programmed to provide a level of safety, functional capability and features beyond the capacity of conventional controls.

#### FEATURES

- Employs a plug-in mounting method
- Uses a microprocessor to improve performance
- The progress of the sequence can be easily determined by status indicator LEDs
- All models have a 4-wire firing rate switching circuit to control an air damper or other auxiliary equipment during startup of the burner.
- Safe start check before and during pre-purge
- Frontal jack plug (Ø 3.5mm) to read the flame signal with a microampere meter.
- An electrical sub base lock (reset and safety limit terminals are swapped) avoids that a Standard model is being used by mistake in a system that needs the VPS function of an Enhanced or Ultimate model. The DBC2000 cannot start in that case.
- Safety shutdown occurs on
  - malfunction of the burner controller
  - failure to ignite the pilot burner or main burner
  - loss of flame during run period
  - opening of air flow switch during pre-purge, start-up, run and post-purge period
  - flame signal detection during standby or pre-purge period
- Integrated Valve Proofing System (Enhanced and Ultimate models only)
- Remote bus communication (Ultimate model only)

#### Contents

Application .....	1
Features .....	1
Specifications .....	2
Dimensions .....	4
Installation and wiring .....	5
Operation .....	9

## SPECIFICATIONS

**Table 1: Model Selection Guide**

Model	Description / Application	Supply voltage
DBC2000E10xx (*)	Standard model	115V or 230V (see detailed specs on page 3)
DBC2000E20xx (*)	Enhanced model	
DBC2000E30xx (*)	Ultimate model	
The Enhanced Model includes a Valve Proofing System. The Ultimate model includes both remote bus communication and a Valve Proofing System.		

(\*) xx depends on supply voltage and timings. For exact model number, please refer to product selection matrix.

**Table 2: Sequence timing**

Waiting for AFS	Waiting for HF	Pre-purge	Ignition	Pilot-only	Main trial	Main stabilization	Post-purge	Flame failure response
300s (max)	300s (max)	35s	3s	3s	3s*	4s*	15s**	1s (max)

\* set to 0s. when DBI function is enabled

\*\* set to 0s. when "no post-purge" feature is enabled

Sequence at flame failure: immediate lock out

**Table 3: Contact ratings**

Terminal	Load	Contact rating
3	Blower / Fan	3A @ $\cos\phi=0.6$
4	Ignition transformer	3A @ $\cos\phi=0.6$
5	Intermittent pilot or main (DBI) valves	3A @ $\cos\phi=0.6$
6	Interrupted pilot	3A @ $\cos\phi=0.6$
7	Main (PI) valves	3A @ $\cos\phi=0.6$
8, 9, 10, 11	Control motor	0.5A @ $\cos\phi=0.6$
21	Alarm	0.5A @ $\cos\phi=0.6$

Total load (based on set): Max 8A (Internal Fuse : 10A)

Total load (based on terminal 4,5,6,7): Max 5A (Internal Fuse : 6.3A)

**Table 4: Flame detection systems**

Detector type	Flame detector model no.	Max. lead wire lengths	Standard stable flame current on jack plug
UV detector	C7027A, C7035A, C7044A	< 100m	4 $\mu$ A (min) 14 $\mu$ A (max)
Flame rod	Rectification type Flame rod, or C7012A/G	< 15m	14 $\mu$ A (min)* 4 $\mu$ A (max)*

\* When using a flame rod, the current on the flame jack plug is inverted. See also Fig 5-2.

## Mains input: Supply voltage

220 to 240Vac -15% +10% 50/60Hz or  
110 to 120Vac -15% +10% 50/60Hz

## Allowable ambient Temperature & Humidity

-10 °C; +60°C  
90% RH max. at 40°C (non-condensing)

## Classification to EN298 (Chapter 4)

F/B/L/L/X/N

Where:

F = Fan assisted

B = Interrupted and Intermittent pilot capable

L (1<sup>st</sup>) = non-volatile lockout after flame loss

L (2<sup>nd</sup>) = non-volatile lockout after flame loss final stage

X = Fixed timings per model number

N = Intermittent operation (non-self-check)

## Approvals

CE certification to EN298:2003 (gas, UV & flame rod)

CE certification to EN230:2005 (oil, UV only)

## Additional approvals:

Lloyds (planned)

EN746-2 compliant

PED (planned)

SIL2 (planned)

Apave (planned)

## Power consumption

9VA

## Protection class

IP40

## Mounting

Plug-in mounting method using sub-base

## Dimensions

103mm x 103mm x 124mm (W x D x H) incl. sub base

## Status indicator LEDs

- Standby
- Purge
- Ignition
- Pilot
- Main
- Modulate
- Flame On
- Alarm

The LEDs will shortly blink as soon as power is applied to the DBC2000 and then as soon as there is a heat demand, indicate the burner sequence.

The LEDs are also used to indicate faults. For example, if a loss of flame signal occurs during RUN, the LEDs for Alarm, Flame and Main will blink the fault code.

## Jack plug

The flame signal can be measured using the jack plug (Ø 3.5mm) on the front, using a microampere meter. The measuring device must be capable of reading microamperes between 2 and 15~20 µA.



## CAUTION

Although the voltage on the jack plug is of low voltage, it is not considered to be safe when touching the wires connected to the jack plug, in case of a malfunction of the device. Therefore avoid touching the lead wires to avoid an electrical shock.

## Reset switch

When the DBC2000 is in lock out condition and the alarm LED blinks, press reset button one time to reset the DBC2000 and stop the alarm. If the heat demand is still present, the DBC2000 will perform the start sequence normally if the fault condition has been resolved, otherwise the lock out will repeat.

If during the lock out condition the DBC2000 is deenergized and power is reapplied afterwards, the DBC2000 will remain in lock out (non-volatile lock out).

A remote reset push button switch can be connected between terminals 15 and 19 (Standard Model) or between terminals 15 and 18 (Enhanced and Ultimate Models). The functionality of the remote reset is the same as the red push button on the front of the device, with one exception:.

The remote reset may occur only 5 times during 15 minutes of operation, while the internal reset button is unlimited.

## Remote communication

- Communication protocol: Profibus or Modbus
- Availability of:
  - Sequence status
  - Fault information
  - Flame signal strength
  - Remote reset (max 5x per 15mins)
  - Remote heat demand
  - Firing rate high/low control
- Transmission speed: 9600bps
- Interface type: RS485 (M+, M-, COM)
- Address select: 1~99 encoder switch



## CAUTION

Although the voltage on the communication lead wires is of low voltage, it is not considered to be safe when touching these wires, in case of a malfunction of the device. Therefore avoid touching the communication lead wires to avoid an electrical shock.

## DIMENSIONS

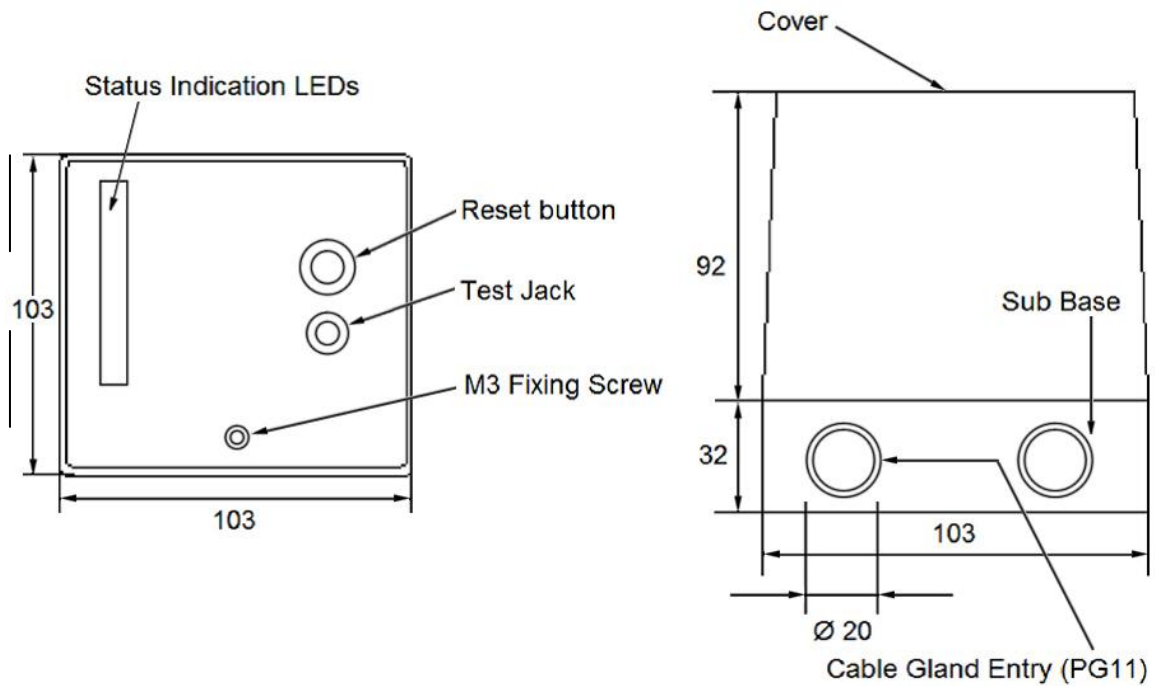

Fig. 1: External Dimensions (in mm)

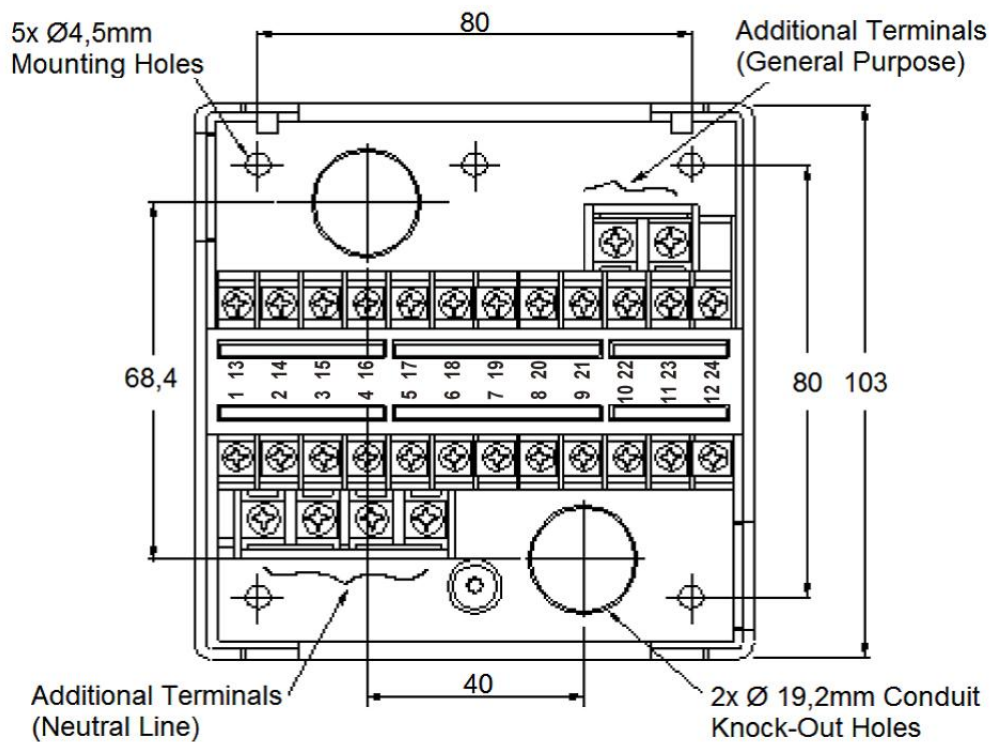

Fig. 2: Mounting dimensions of sub-base and terminal layout

## INSTALLATION AND WIRING



### CAUTION

#### INSTALLATION

##### When Installing this Product...

1. Read these instructions carefully. Failure to follow them could damage the product or cause a hazardous condition.
2. Check the ratings given in the instructions and marked on the product to make sure the product is suitable for the application.
3. Installer must be a trained, experienced, flame safeguard service technician.
4. After installation is completed, check out the product operation as provided in these instructions.



### WARNING

#### Fire or Explosion Hazard.

**Can cause property damage, severe injury, or death.**

Carefully follow safety requirements when installing a burner control.



### CAUTION

#### Electrical Shock Hazard or Equipment/Control Damage.

Disconnect power supply before beginning installation, to avoid electrical shock or equipment damage..

### IMPORTANT

1. Wiring connections for the relay modules are unique; refer to Fig. 3-2 or the appropriate Specifications for individual subbase wiring.
2. Wiring must comply with all applicable codes, ordinances and regulations.
3. Wiring must comply with NEC Class 1 (Line Voltage) wiring.
4. Loads connected to the DBC2000E must not exceed those listed on the relay module label or the Specifications; see Table 3.
5. Limits and interlocks must be rated to simultaneously carry and break current to the ignition transformer and fuel valve(s).
6. All external timers must be listed or component recognized by authorities who have proper jurisdiction.
7. For on-off gas-fired systems, some authorities

who have jurisdiction prohibit the wiring of any limit or operating contacts in series between the flame safeguard control and the main fuel valve(s).

8. Two UV flame detectors can be connected in parallel.
9. This equipment generates, uses and can radiate radio frequency energy and, if not installed and used in accordance with the instructions, can cause interference with radio communications. It has been tested and found to comply with the limits for a Class B computing device of Part 15 of FCC rules, which are designed to provide reasonable protection against such interference when operated in an industrial or commercial environment. Operation of this equipment in a residential area can cause interference, in which case, the users, at their own expense, may be required to take whatever measures are required to correct this interference.
10. This digital apparatus complies with the requirements as stated in the EN298:2003.
11. Do not install the Burner Controller under any circumstances in the following locations.
  - ① Where chemicals or corrosive gases are present, such as ammonia, sulfur, chlorine, ethylene compounds, acids, etc.
  - ② Install the relay module where the relative humidity never reaches the saturation point. The relay module is designed to operate in a maximum 85% relative humidity continuous, noncondensing, moisture environment. Condensing moisture can cause a safety shutdown or damage the device.
  - ③ Where temperatures exceed the maximum specification for this device.
  - ④ Where excessive continuous vibration exists.
12. Do not bundle power wiring and high voltage ignition cable with the flame detector wiring, or run them in parallel within the same conduit. High voltage cables must be kept separated at least 10 cm from the Burner Controller.
13. Use proper grounding work in accordance with the engineering standards for electrical equipment
14. Connect the high voltage cable of the ignition transformer properly to the ignition electrode. A poor connection can cause an electrical shock or damage the equipment. Additionally the ignition transformer must be properly grounded according the standards.

## REMOVE THE RELAY MODULE FROM ITS SUB BASE AND FIX THE SUB BASE

1. Loosen the M3 fixing screw as shown in Fig. 1 by about eight turns using a Philips head screwdriver.
2. Take the subbase and cover with both hands and unfold them gently. Fold the relay module upwards, the turning point is on the top. Do not apply excessive force, otherwise damage may occur.
3. Punch out the needed conduit knockout holes for the wiring as shown in Figs 1 and 2, and install the wiring conduit(s).
4. Using the fixing screws, mount the subbase in the specified position.

## WIRING THE RELAY MODULE BOTTOM TERMINALS

1. For applications with a UV detector, remove the jumper terminal located at the terminal block on the bottom of the relay module.
2. For applications using remote communication, connect communication cable to "BUS" terminal located at the terminal block on the bottom of the relay module. In addition, set the communication address using the rotary switches at the bottom of the relay module.

## WIRING THE SUB BASE

1. Fig. 2 shows the layout of the terminals on the subbase, and Figs. 3-1 to 3-3 show examples of connections to external equipment. Regarding the wiring to the flame detector, refer to Fig. 4.
2. When using Intermittent Pilot, connect the pilot valve to Terminal 5. Connect the main valves to Terminal 7 (Enhanced and Ultimate models: connect main valve 1 to Terminal 7 and main valve 2 to Terminal 12 for the VPS function)
3. When using Interrupted Pilot, connect the pilot

valve to Terminal 6. Connect the main valves to Terminal 7 (Enhanced and Ultimate models: connect main valve 1 to Terminal 7 and main valve 2 to Terminal 12 for the VPS function)

4. When using direct ignition (DBI), jumper Terminals 15 and 22. And connect the Main(DBI) valves to Terminal 5.
5. When not using purge position interlock, jumper Terminals 15 and 16.
6. When not using start position interlock, jumper Terminals 13 and 17.
7. When not purge and start position interlocks, jumper Terminals 15 and 16 as well as Terminals 13 and 17 simultaneously.
8. Connect the safety switch circuit (lockout interlocks) between Terminals 15 and 18. The safety switch circuit must be closed always, otherwise a lockout occurs immediately.
9. For non-floating mains power grids (Neutral to Ground), connect the Line-L to Terminal 1 and the Line-N to Terminal 2. Use a correct fuse: 10A fast blow maximum.
10. Check all wiring circuits and assure that the correct fuse is installed. Check the correct voltage.
11. Finally plug the relay module on to its sub base and fix it with the M3 fixing screw. Do not overtight the screw.
12. When using a surge absorber, connect it between Terminal 2 and application ground.
13. Connect the mains supply voltage using 0.75mm<sup>2</sup> or larger lead wire.
14. Never connect blank stripped wires to the wiring sub base. Loose wire strands may cause short circuits to electrically safe contacts which may cause an electrical shock hazard.



**Always use cable lugs to attach the wires to the sub base.**

See Fig 2-1 for dos and don'ts about wiring.

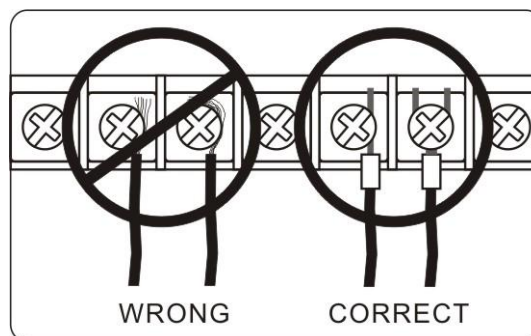

Fig. 2-1: Wiring the sub base terminals

DBC2000E standard model terminals	DBC2000E enhanced and ultimate model terminals
1 Line Voltage (L)	1 Line Voltage (L)
2 Line Voltage (N)	2 Line Voltage (N)
3 Blower / Fan (O)	3 Blower / Fan (O)
4 Ignition Transformer (O)	4 Ignition Transformer (O)
5 Intermittent Pilot or Main (DBI) Valves (O)	5 Intermittent Pilot or Main (DBI) Valves (O)
6 Interrupted Pilot (O)	6 Interrupted Pilot (O)
7 Main (PI) Valves (O)	7 Main (PI) Valve 1 (O)
8 Firing Rate common (I)	8 Firing Rate common (I)
9 Firing Rate Modulate (O)	9 Firing Rate Modulate (O)
10 Firing Rate Purge (O)	10 Firing Rate Purge (O)
11 Firing Rate Start (O)	11 Firing Rate Start (O)
12 Post-purge Select (I)	12 Main (PI) Valve 2 (O)
13 Low Fire Rate Feedback Override (I)	13 Low Fire Feedback Override (I)
14 Air Flow Switch (I)	14 Air Flow Switch (I)
15 Control Switches Common (O)	15 Control Switches Common (O)
16 HF - Purge Position Interlock (I)	16 HF - Purge Position Interlock (I)
17 LF - Start Position Interlock (I)	17 LF - Start Position Interlock (I)
18 Safety Limits (I)	18 Remote Reset (I)
19 Remote Reset (I)	19 Safety Limits (I)
20 Heat Demand (I)	20 Heat Demand (I)
21 Alarm (O)	21 Alarm (O)
22 PI/DBI select (I)	22 VPS Pressure Switch (I)
23 Flame Detector (F)	23 Flame Detector (F)
24 Ground (G)	24 Ground (G)

Note: terminals 18 and 19 are swapped for the Standard and Enhanced/Ultimate models. This is to prevent that a Standard model can be used by mistake in a system that is wired for an Enhanced or Ultimate model.

Fig. 3-1: Terminal layout

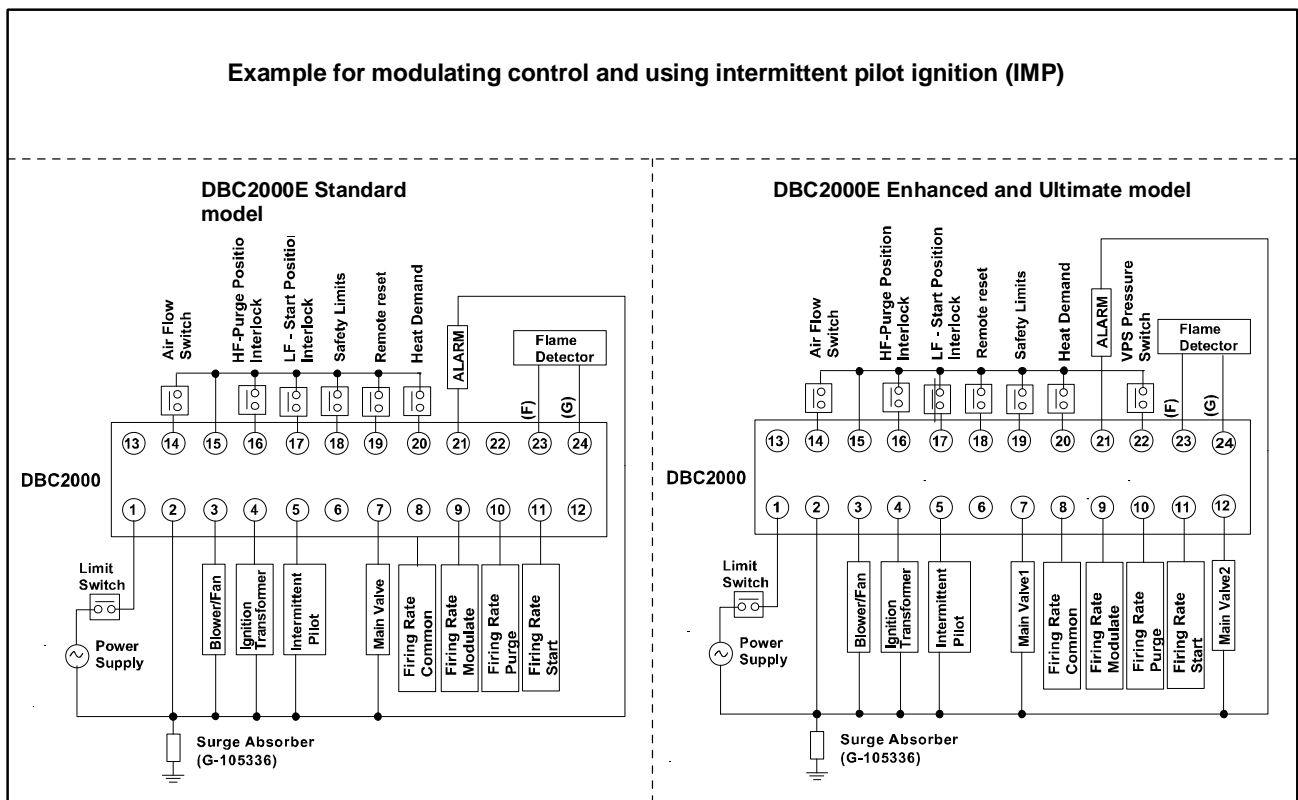

Fig. 3-2: Example1 of wiring to external equipment

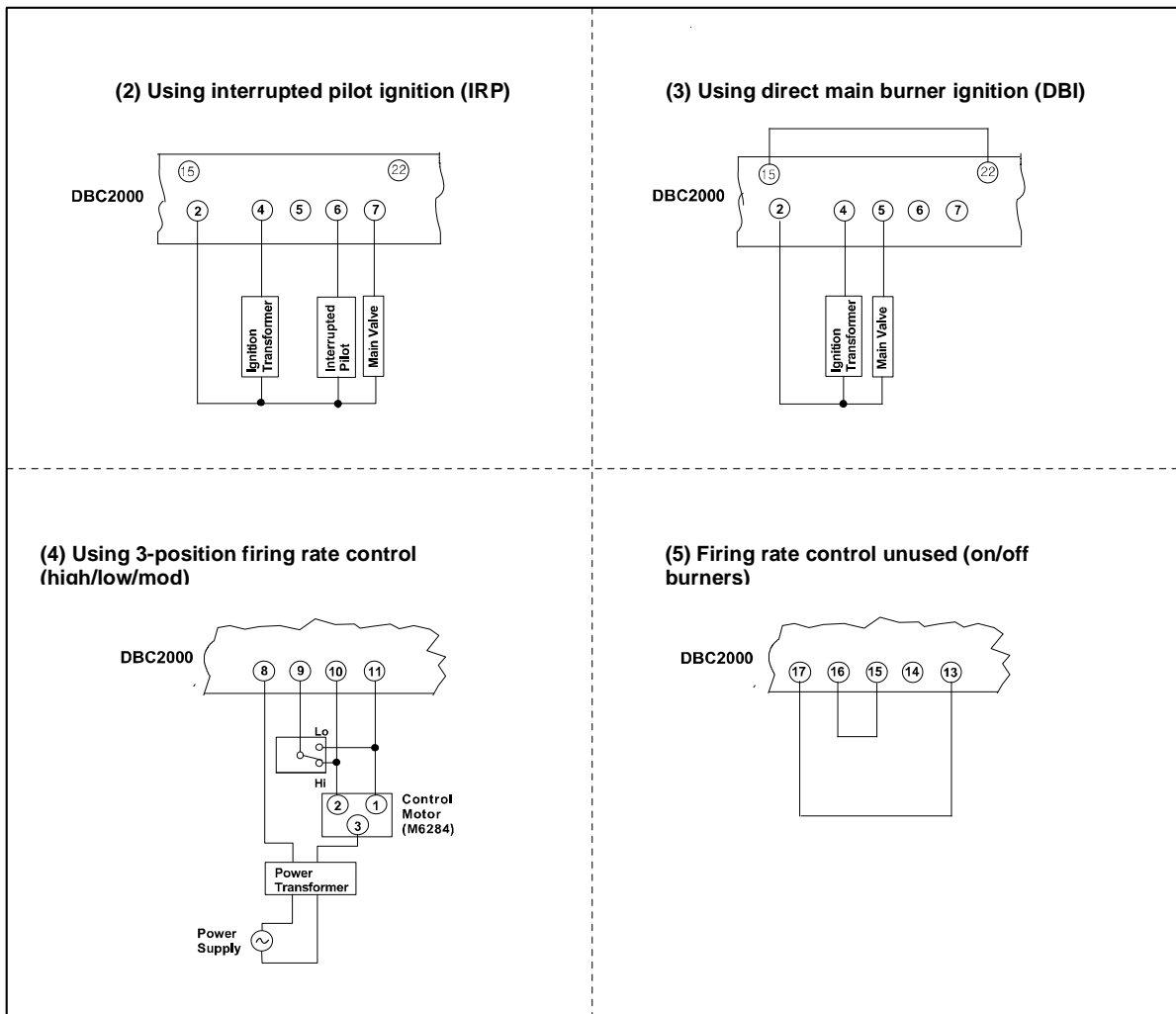

Fig. 3-3: Example 2 of wiring to external equipment

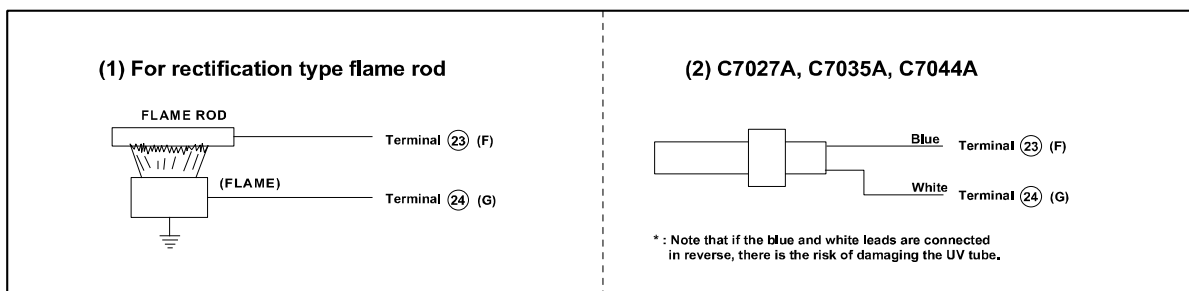

Fig. 4: Connection to flame detector

## ⚠ CAUTION

There is line voltage on flame sensor inputs. Don't touch the lead wires of the UV detector or the flame sensing electrode to avoid an electrical shock.



## OPERATION

### 1. NORMAL OPERATION

Power SW and Controllers	Operation of DBC2000 and device	Indicator LED *
Power SW ON, Limit SW ON	The power supply voltage is applied across Terminal 1 and 2. When no flame signal is present, the combustion airflow switch is opened (T14=OFF) and safety lockout circuit is closed (ON), it is possible to start.	●○○○○○○○
Controller ON	The blower is energized (T3). Firing rate goes to PURGE position. Air flow switch closes (T14=ON) as soon as air flow is present.	●●○○○○○○○
	The pre-purge timer starts counting as soon as PURGE interlock is closed (T16=ON).	
	After the completion of pre-purge timing, firing rate goes to START position.	
	The ignition wait timer starts counting as soon as the START position interlock is closed (T17=ON).	
	After completion of the ignition wait timing, the Ignition sequence starts. The Ignition transformer is energized. The Intermittent and Interrupted pilot valve outputs are energized (T5 and T6).	●○●○○○●○
	When a flame is detected after the ignition trial has ended (Safety1), the pilot stabilization time starts.	●○○●○○●○
	After completion of the pilot-stabilization time, the Main valves are energized (T7=ON). Note: Enhanced Model: also (T12=ON). The Main trial for ignition takes place (Safety2).	●○○○●○●○
	After completion of the main trial time, Interrupted pilot valve is deenergized (T5=OFF). The Main stabilization time starts.	●○○○●○●○
	After completion of the main stabilization time, the firing rate goes to modulation position and releases control to an external modulation device.	●○○○○●●○
Controller OFF	The intermittent pilot valve and main valves are deenergized (T6=OFF and T7=OFF). Note: Enhanced Model: also (T12=OFF). Firing rate moves to PURGE position. The post-purge timing takes place.	●●○○○○○○○
	After the completion of the postpurge time, the blower is deenergized and firing rate moves to START position.	●○○○○○○○○○
	After the air flow switch goes OFF, DBC2000E returns to the STANDBY condition, waiting for the next heat demand.	

\* For LED indication, ○ means 'off', ● means 'illuminated', ● means 'blinking'.

\* The LEDs are arranged in the following order: Standby, Purge, Ignition, Pilot, Main, Modulate, Flame and Alarm at the left front side of the DBC2000.

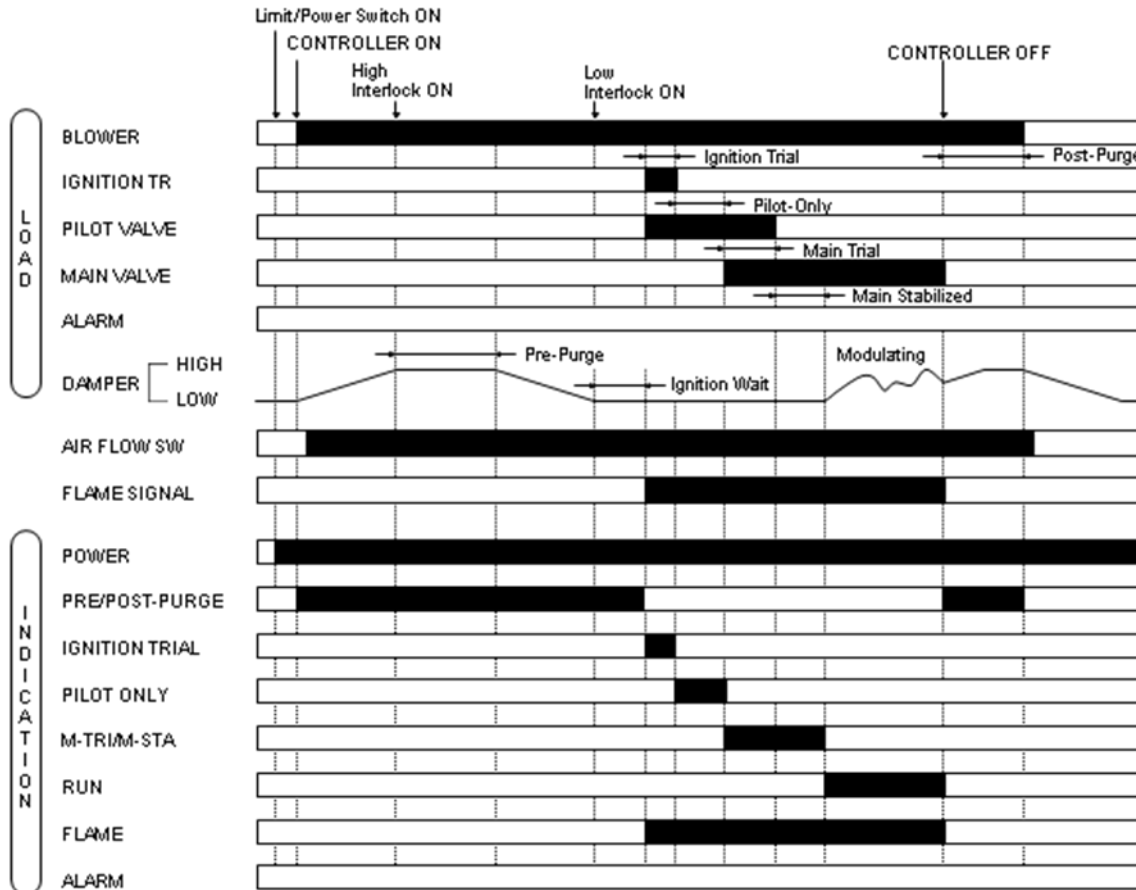

Fig. 5: Normal operation

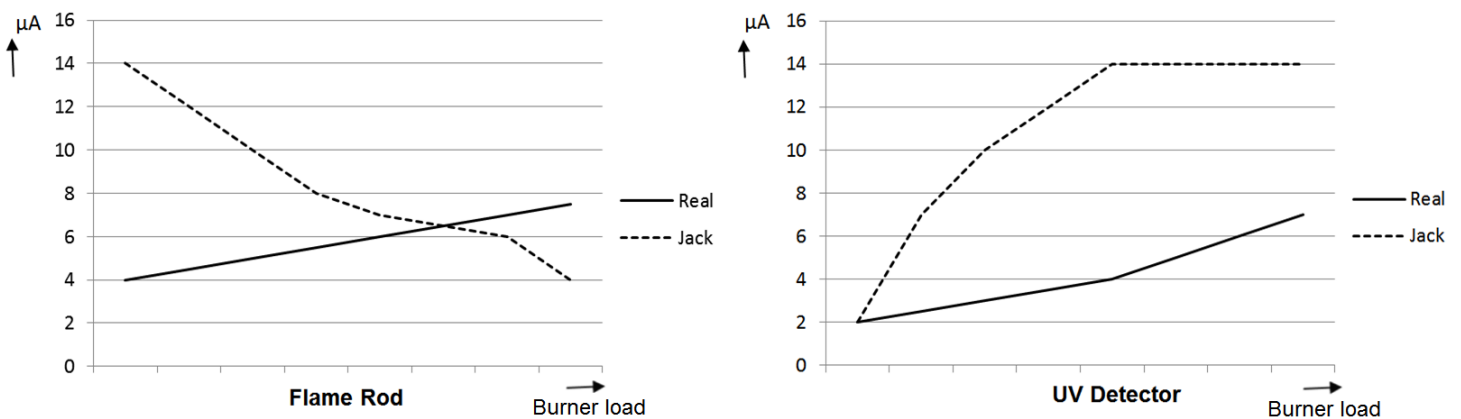

Fig. 5-1: Real flame current versus reading on frontal jack plug.

**Note:**

The flame signal strength on the flame current jack plug is only for reference and may vary between different DBC2000 devices.

When measuring the flame signal current directly in the flame sensor wiring whilst:

1. Using a flame rod, the (multi-)meter will show the real flame current in  $\mu\text{A}$ .
2. Using a UV sensor (C7027, C7035 or C7044), the current in the sensor lead wires will be in the range of 20...25mA (inverted values).

## 2. ERROR TYPES AND SAFE SHUTDOWN

If a critical error related to safety operation (such as a loss of flame, opening of the air flow switch during the ignition trial and run sequence) is detected, the DBC2000 instantly goes into lock-out and goes to pre-purge status.

If a non critical error (such as opening of the air flow switch opening during post-purge) is detected, DBC2000 holds the sequence for lock-out time and then goes into lock-out.

For all types of errors, the status LEDs indicate the status information to the operator.

Fig. 6 to Fig. 13 show the sequence of DBC2000 in case of some error. And Table.5 shows the status of LEDs for each error.

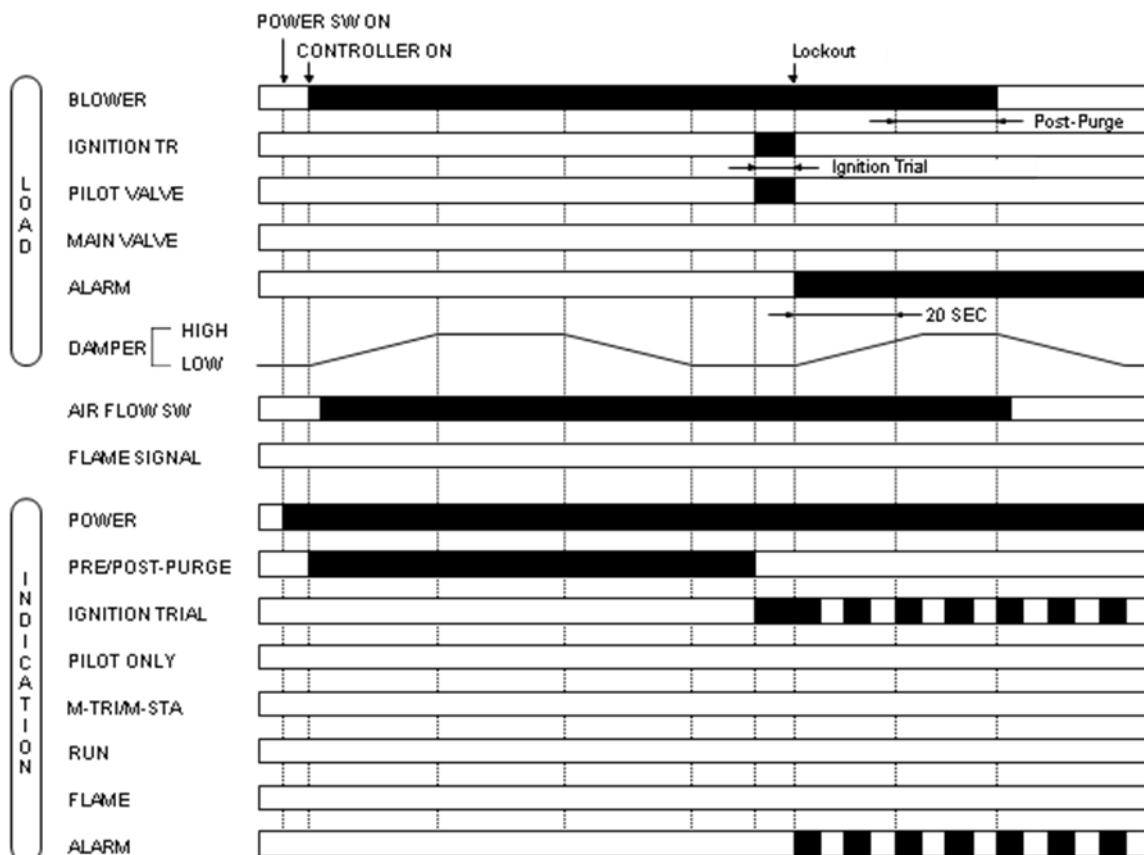

Fig. 6: Failure to ignite the pilot

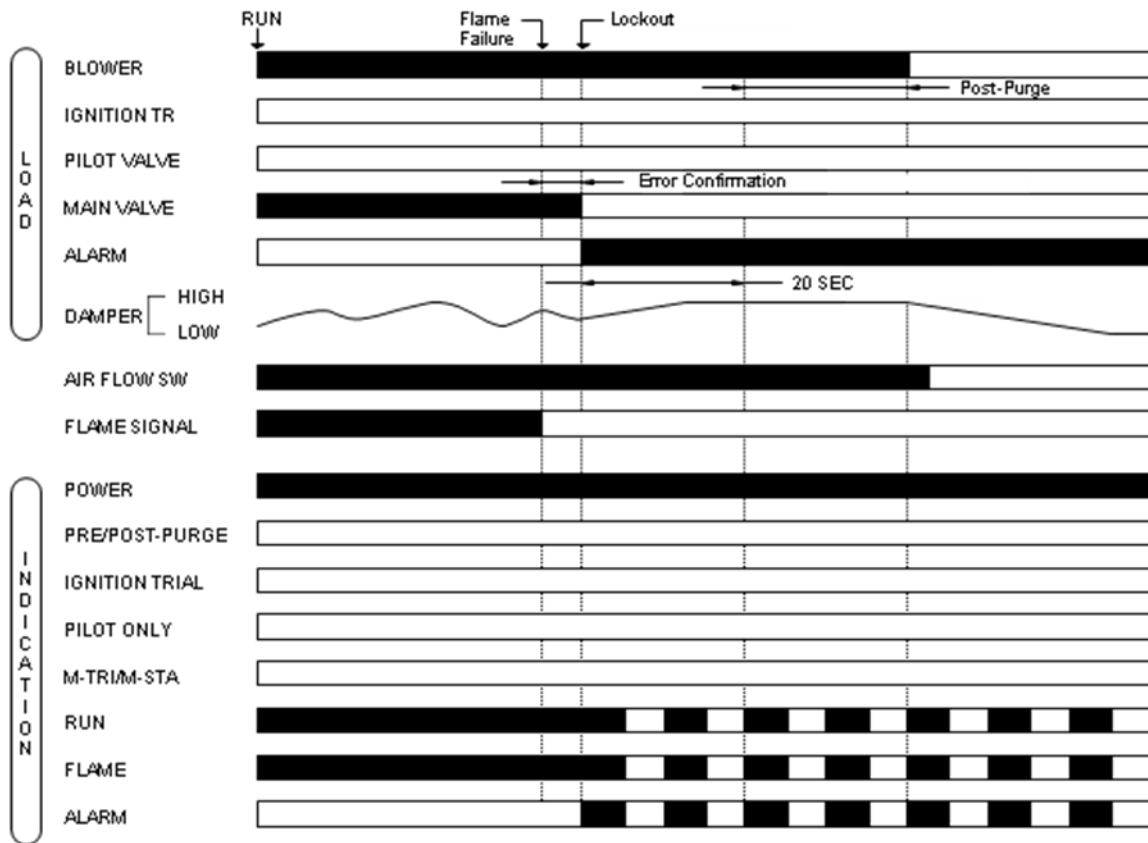

Fig. 7: Flame failure during run period

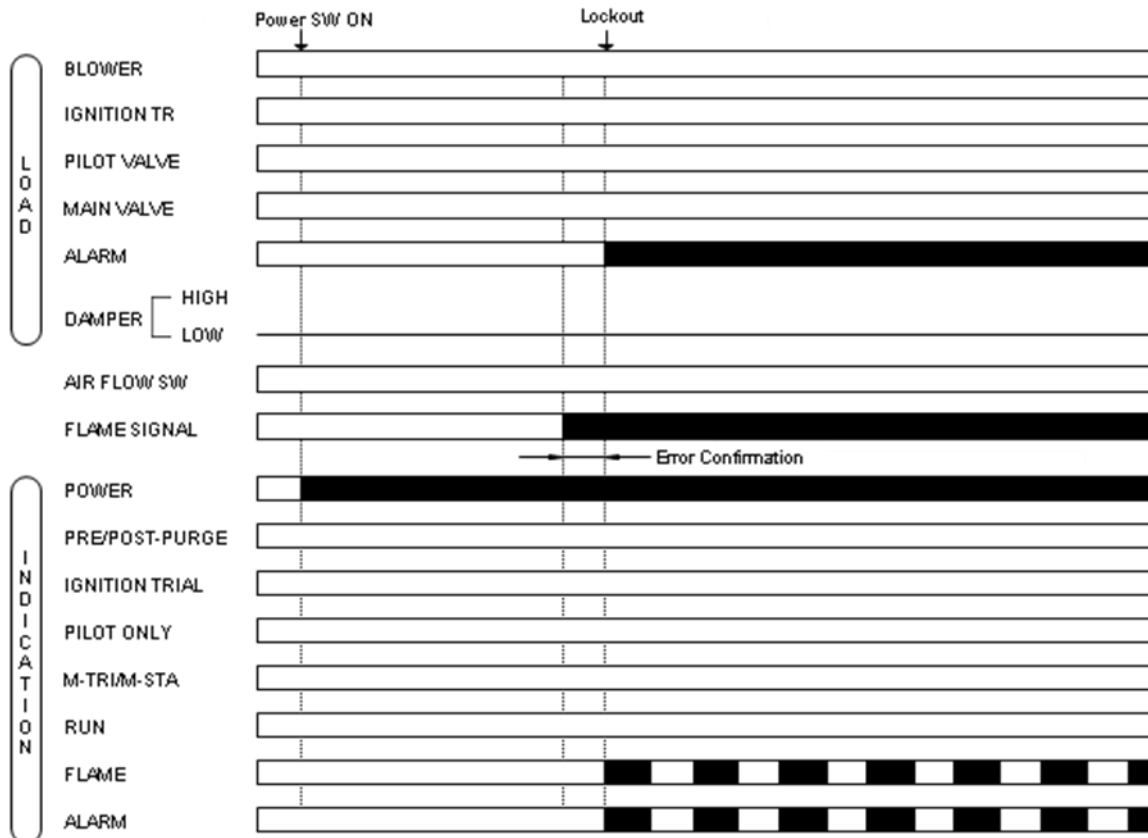

Fig. 8: When false flame signal is generated during standby

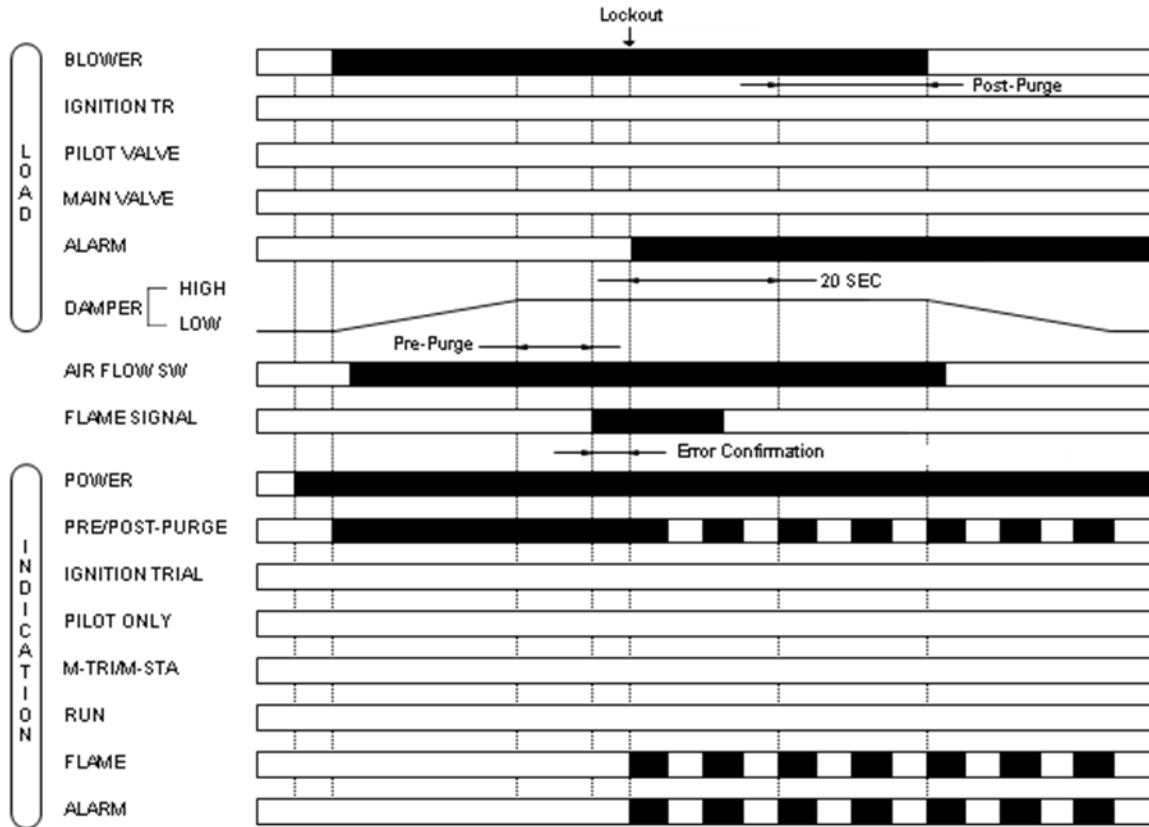

Fig. 9: When false flame is generated during pre-purge

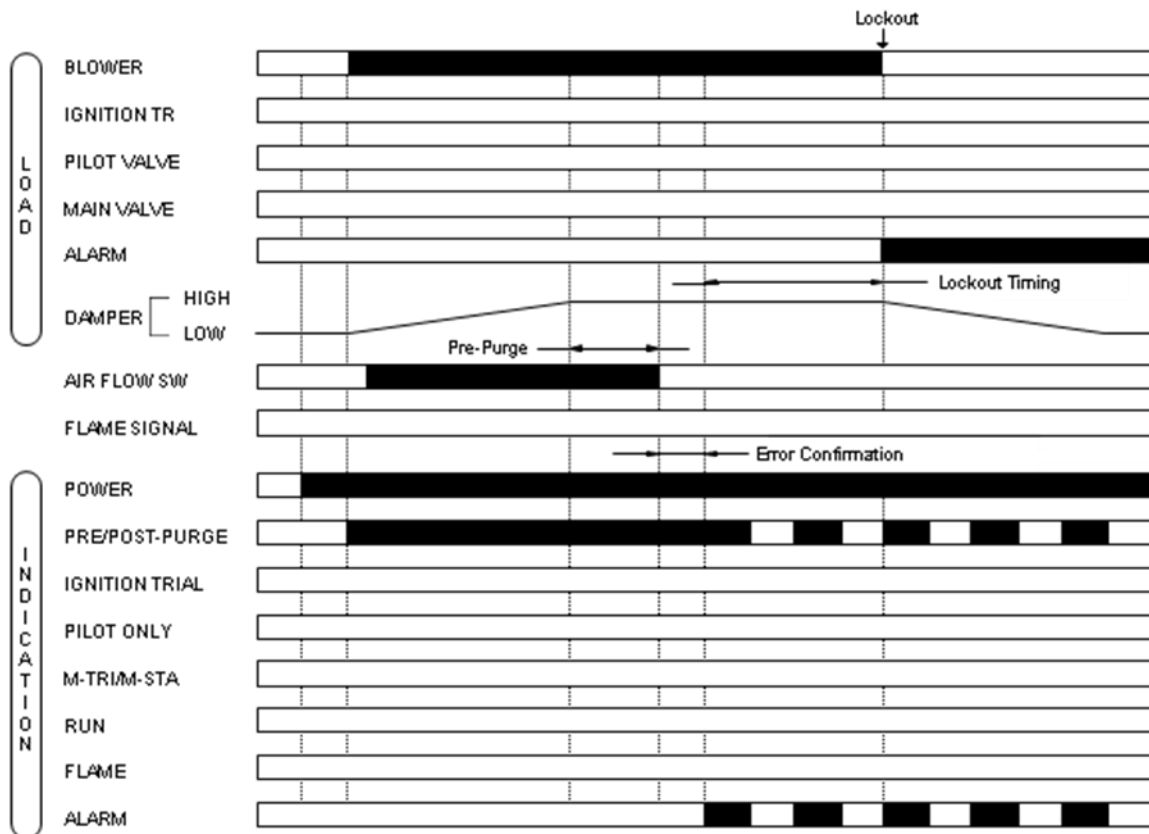

Fig. 10: When air flow switch goes OFF during pre-purge, and continues after the Lockout timing

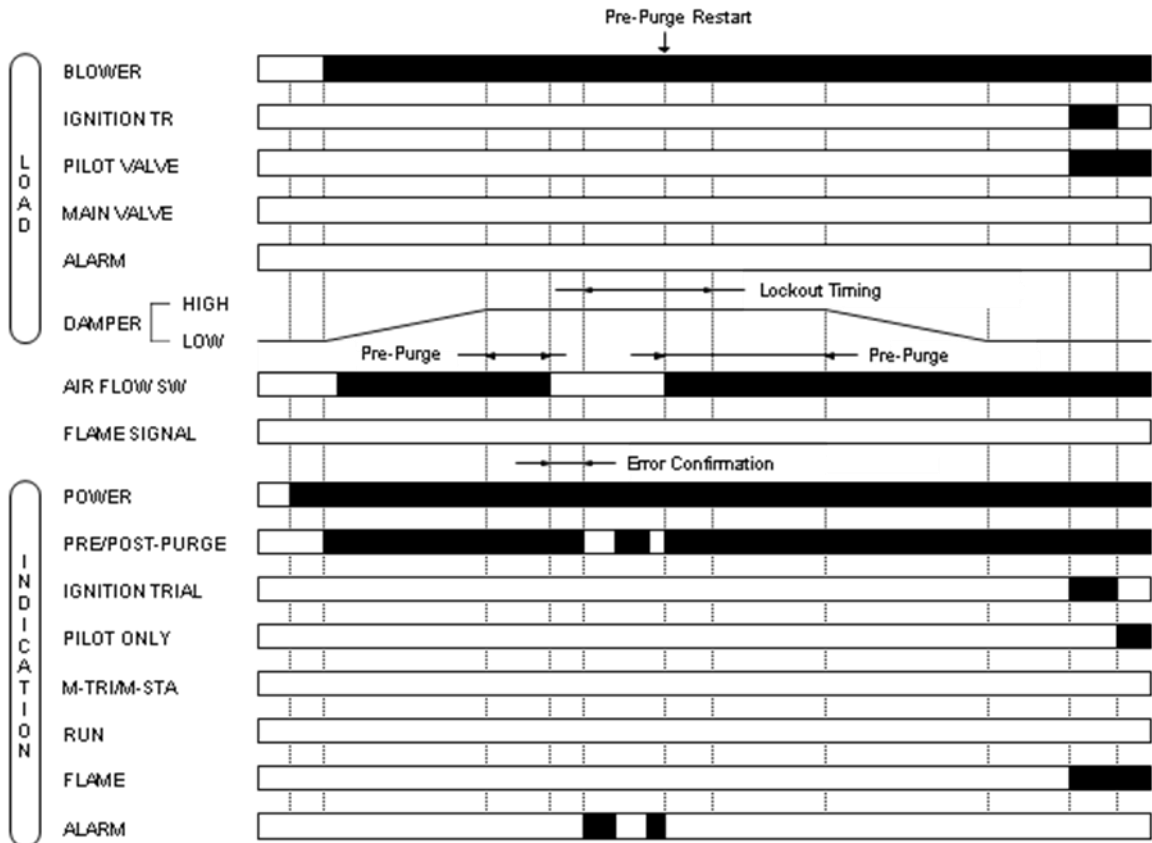

Fig. 11: When air flow switch goes OFF during pre-purge, and then ON again within Lockout timing

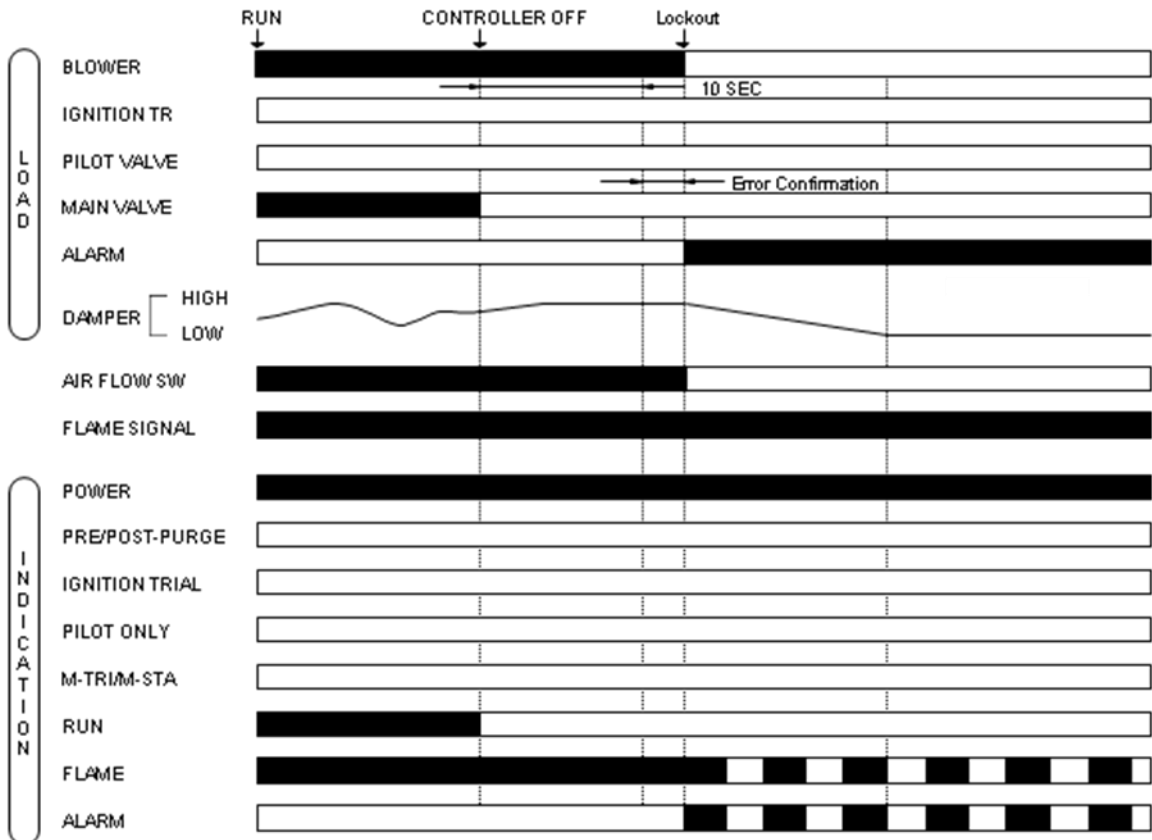

Fig. 12: When flame signal remains present after the end of heat demand

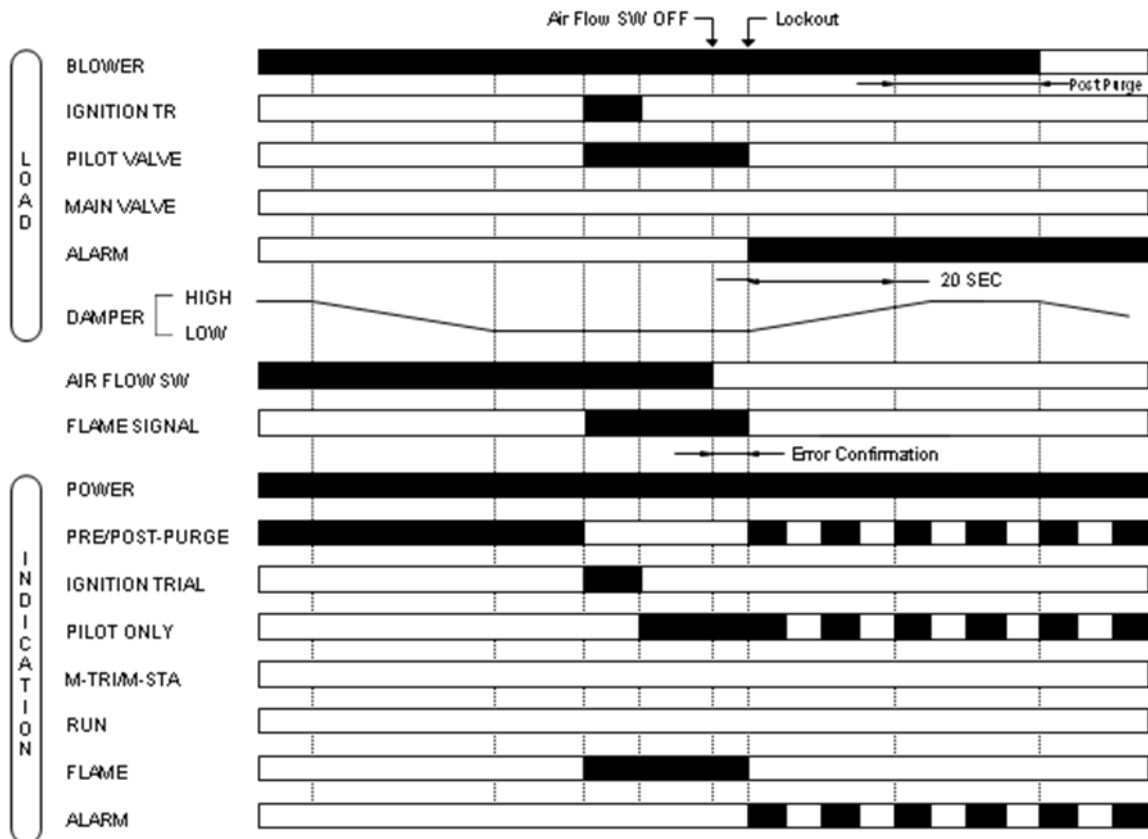

Fig. 13: When air flow switch goes OFF during Pilot stabilization

**Table 5: Error condition and LED status**

Sequence	Error condition	Indicator LED status (*1)
Standby (*2)	Air flow switch remains ON (closed) for more than 5 minutes, or START position interlock switch remains OFF (opened) for more than 5 minutes.	●●○○○○○○●
	Flame signal is present	●○○○○○○●●
	Blower motor is energized	●○○●○○○○●
Pre-purge	Air flow switch remains OFF for more than 5 minutes after the heat demand has started.	●●○○○○○○●
	PURGE position interlock switch remains OFF for more than 5 minutes after the heat demand started.	●●●○○○○●
	Both PURGE and START position interlocks ON at the same time during prepurge period	●●●○○○○●
	START position interlock remains OFF more than 5 minutes after pre-purge has finished	●●●○○○○●
	Air flow switch goes ON within 5 minutes after the heat demand started, but air flow switch goes OFF again.	●●○○○○○○●
	Flame signal is present.	●●○○○○○○●
Ignition Standby	Air flow switch goes OFF	●●○○○○○○●
	Flame signal is present	●●○○○○○○●
Pilot Ignition	Air flow switch goes OFF	●●○○○○○○●
	Ignition failure (flame signal is present during ignition-trial).	●○○○○○○●
Pilot only	Air flow switch goes OFF	●●○○○○○○●
	No flame signal	●○○○○○○●
Main ignition	Air flow switch goes OFF	●●○○○○○○●
	No flame signal	●○○○○○○●
Main ignition Stabilization	Air flow switch goes OFF	●●○○○○○○●
	No flame signal	●○○○○○○●
Run	Air flow switch goes OFF	●●○○○○○○●
	No flame signal	●○○○○○○●
Post-purge	No power is supplied to Terminal 3 because of internal relay contact failure.	●●○○○○○○●
	Flame signal is present for more than 10 seconds after heat demand has ended.	●○○○○○○●
	Air flow switch keeps ON more than 2 minutes after post-purge.	●●○○○○○○●

\*1 : For LED indication, ○ means 'off', ● means 'illuminated', ● means 'blinking'.

The LEDs are arranged in the following order: Standby, Purge, Ignition, Pilot, Main, Modulate, Flame and Alarm at the left front side of the DBC2000.

\*2 : If an error occurs during Standby, the DBC2000 will not lock-out but LEDs indicate the current error status.

In this case, the DBC2000 cannot start before the error is resolved.



## Sales Affiliates ECC OEM Europe

### Germany, Austria, Switzerland, Liechtenstein

Honeywell GmbH - Harchofweg - 74821 Mosbach - GERMANY  
Ph.: (+49) 6261 81 0 - Fax: (+49) 6261 81 461 - OEM-SalesCentralEurope@Honeywell.com - www.honeywell.com/sites/de

### France

Honeywell SA - Parc Technologique de St. Aubin - Bâtiment Mercury BP87 - 91193 Gif-Sur-Yvette Cedex - FRANCE  
Ph.: (+33) 1 60 19 80 00 - Fax: (+33) 1 60 19 81 81 - OEM-SalesWestEurope@Honeywell.com - www.honeywell.com/sites/fr

### Italy

Honeywell srl - Via Philips n.12 - 20052 Monza - ITALY  
Ph.: (+39) 0 39 21 65 1 - Fax: (+39) 0 39 21 65 402 - OEM-SalesSouthEurope@Honeywell.com - www.honeywell.it

### Spain - Portugal

Honeywell S.A. - Josefa Valcárcel 24 - 28027 Madrid - SPAIN  
Ph.: (+34) 9 13 13 61 00 - Fax: (+34) 9 13 13 61 27 - OEM-SalesSouthEurope@Honeywell.com - www.honeywell.com/sites/es

### United Kingdom

Honeywell Control System Ltd. - Unit 2 President Buildings, Savile Street East - S Yorks S4 7UQ - SHEFFIELD - UNITED KINGDOM  
Ph.: (+44) 114 288 0920 - OEM-SalesUK@Honeywell.com - www.honeywell.com/sites/uk

### Netherlands, Belgium, Luxembourg, Scandinavia

Honeywell B.V. - Laarderhoogweg 18-20 - 1101 EA Amsterdam Z.O. - THE NETHERLANDS  
Ph.: (+31) 2 05 65 69 11 - Fax: (+31) 2 05 65 66 00 - OEM-SalesWestEurope@Honeywell.com - www.honeywell.com/sites/nl

### Turkey

Honeywell A.S. - Cayiriyolu Sok. No:7 - Uccgen Plaza, Kat:7 - Isenkenoy 34752 Istanbul - TURKEY  
Ph.: (+90) 216 578 7120 - Fax: (+90) 216 575 6637 - OEM-SalesSouthEurope@Honeywell.com - www.honeywell.com/sites/tr

### Slovakia

Honeywell s.r.o. - Mlynske Nivy 71 - PO Box 75 - 82007 Bratislava 27 - SLOVAKIA  
Ph.: (+421) 2 322 622 11 - Fax: (+421) 2 322 622 55 (54) - OEM-SalesEasternEurope@Honeywell.com - www.honeywell.sk

### Czech Republic

Honeywell spol. s.r.o. - V parku 2326/18 - 14800 Prague - CZECH REPUBLIC  
Ph.: (+420) 242 442 111 (255) - Fax: (+420) 242 442 181 - OEM-SalesEasternEurope@Honeywell.com - www.honeywell.com/sites/cz

### Kazakhstan

Honeywell Automation Controls - 42, Timiryazev Str. - 050057 Almaty - KAZAKHSTAN  
Ph.: (+7) 727 2747 747 - Fax: (+7) 727 2752 252 - OEM-SalesEasternEurope@Honeywell.com - www51.honeywell.com/ru

### Ukraine

IP Honeywell Ukraine - Silver Centre - 4, Ivana Lipse ave. - 03680 Kiev - UKRAINE  
Ph.: (+380) 44 351-15-50 (52) - Fax: (+380) 44 351-15-51 (53) - OEM-SalesEasternEurope@Honeywell.com - www51.honeywell.com/ru

### Russia

ZAO Honeywell - Luzhniki 24 - 119048 Moscow - RUSSIA  
Ph.: (+7) 495 796 9800 (35) - Fax: (+7) 495 796 9894 (797 9370) - OEM-SalesEasternEurope@Honeywell.com - www51.honeywell.com/ru

### Hungary

Honeywell Kft. - Petnehazy U. 2-4 - 1139 Budapest - HUNGARY  
Ph.: (+36) 1 451 4300 (46) - Fax: (+36) 1 451 4343 - OEM-SalesEasternEurope@Honeywell.com - www51.honeywell.com/hungary

### Poland

Honeywell Sp.z.o.o. - Domaniewska 39b - 02672 Warsaw - POLAND  
Ph.: (+48) 22 60 60900 (50) - Fax: (+48) 22 60 60983 - OEM-SalesEasternEurope@Honeywell.com - www.honeywell.com/sites/pl

### Romania

Honeywell Romania SRL - Calea Floreasca 169A - 014462 Bucharest - ROMANIA  
Ph.: (+40) 312 24 3000 (3) - Fax: (+40) 212 31 6439 - OEM-SalesEasternEurope@Honeywell.com - www.honeywell.com/sites/romania

