



SQK33.00



SQL33...
SQL83.00



Electromotoric Actuators

for valves with 90° angle of rotation

SQK33.00
SQL33...
SQL83.00

- **SQK33.00** operating voltage AC 230 V
- **SQL33...** operating voltage AC 230 V
- **SQL83.00** operating voltage AC 24 V
- **3-position control signal**
- **Nominal angle of rotation 90°**
- **Auxiliary switch and potentiometer for extra functions**
- **Manual adjuster and position indicator**
- **Reversible electric motor**





Use

For use in heating, ventilation and air conditioning systems to operate type VKF41... butterfly valves and type VBF21..., VBG31..., VBI31..., VCI31 3-port and 4-port slipper valves as well as valves from other manufacturers (refer to «Equipment combinations»).

Type summary

Type	Operating voltage	Positioning signal	Positioning time for 90° at 50 Hz	Positioning force
SQK33.00	AC 230 V	3-position	125 s	5 Nm
SQL33.00				12.5 Nm
SQL33.03			30 s	10 Nm
SQL83.00	AC 24 V		125 s	12.5 Nm

Mounting kits

Type	Actuators	For valves	
ASK31 	SQK33.00	Slipper valves VBF21... (DN 65...150)	
ASK32 		Slipper valves VBF21...(DN 40...50), VBG31..., VBI31..., VCI31...	
ASK33 		SQL33.00 SQL33.03 SQL83.00	Butterfly valves VKF41... (DN 40...200)
ASK40 		Slipper valves from other manufacturers	
ASK41 			

Accessories

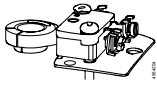
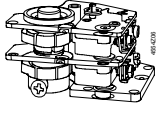
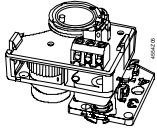
Type	Description	For actuators	Mounting position
ASC9.5 	Auxiliary switch	SQK33.00 ¹⁾ SQL33... SQL83.00	1 x ASC9.5 or 1 x ASC9.4 or 1 x ASZ7.4 (only one accessory at a time can be mounted)
ASC9.4 	Double auxiliary switch		
ASZ7.4 	Auxiliary switch and potentiometer 1000 Ω		

¹⁾ In SQK33.00 only the ASC9.5 auxiliary switch can be installed.

Order

The actuator, slipper valve, butterfly valve, mounting kit ASK... and any accessories must be ordered separately.

When ordering please specify the quantity, product name and type code.

Example

1 actuator SQL33.03
1 mounting kit ASK31
1 auxiliary switch with potentiometer ASZ7.4

Delivery

The actuator, slipper valve or butterfly valve, mounting kit ASK... and accessories are packed separately and delivered as individual items..

Equipment combinations

	Electromotoric actuator			Mounting kit	Data sheet	
	Valves	SQK33.00	SQL33...			SQL83.00
3-port slipper valve	VBF21...	DN 40...50		ASK32	N4241	
			DN 65...150			ASK31
	VBI31...	DN 20...40 (¾...1½")			ASK32	N4232
	VBG31...					N4233
4-port slipper valve	3-port valves of other manufacturers	DN 15...40 (¾...1½")	DN 15...125 (¾...2")		ASK40	N4291
				ASK41		
4-port slipper valve	VCI31...	DN 20...40 (¾...1½")			ASK32	N4252
	4-port valves of other manufacturers	DN 15...40 (¾...1½")	DN 15...200 (¾...2")		ASK40	N4291
				ASK41		
Butterfly valves	VKF41...	DN 40	DN 40...200		ASK33	N4131

Function / mechanical design

These electromotoric actuators require no maintenance. They have a reversible synchronous motor and reduction gears with self-lubricating sinter bearings.

The actuator is driven by a 3-position signal from the controller and generates a rotary motion which is transferred via a driver to the butterfly valve, the 3-port or 4-port slipper valve.

The actuators are supplied with a 90° angle of rotation suitable for use with Siemens butterfly and slipper valves. During automatic operation, rotation is limited by two built-in end-switches. For non-Siemens valves, the angle of rotation in the range 70° to 180° can be selected by repositioning the switching cams..

The direction of operation of the actuator can be reversed (refer to «Commissioning»).

Direction of rotation of the actuator on delivery:

- Voltage at Y1 = Clockwise rotation
- Voltage at Y2 = Anti-clockwise rotation
- No voltage = No rotation; actuator fixed in relevant position

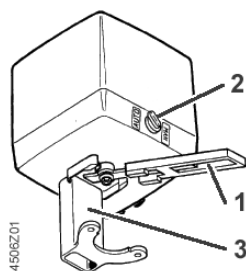

- 1 Manual lever, rotation is limited by built-in stop
- 2 Rotary «AUTO» / «MAN» selector
- 3 Yoke (e.g. mounting kit ASK31)

When the selector is set to «MAN», the valve can be operated with a manual lever.

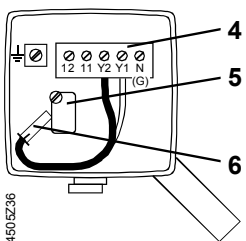

- 4 Terminal strip
- 5 Double end switch (always factory-installed)
- 6 Plug for reversing direction of rotation

Engineering notes

Electrical installation

The actuators must be electrically connected in accordance with local regulations and with the connection diagrams.



Regulations and requirements to ensure the safety of people and property must be observed at all times.

If additional functions are to be controlled by the actuator, the ASC9... (auxiliary switch) or ASZ7.5 (auxiliary switch / potentiometer) must be fitted. The relevant switching point(s) and zero-ohm position must be noted in the plant documentation

Mounting notes

Overview of Mounting Instructions

Type	Mounting Instructions	
ASK31	M4290.1	4 319 5596 0
ASK32	M4290.2	4 319 5597 0
ASK33	M4111.1	4 319 5595 0
ASK40	M4291.1	4 319 5534 0
ASK41	M4291.2	4 319 5535 0

Type	Mounting Instructions	
ASC9.4	G4506.5	4 319 5537 0
ASC9.5	G4506.7	4 319 5557 0
ASZ7.4	G4506.6	4 319 5538 0

The valve and actuator can be assembled straightforwardly on site. There is no need for special tools.

Orientation

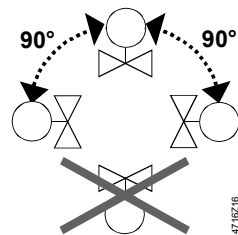

Commissioning notes

When commissioning the complete motorized valve consisting of actuator, mounting kit and valve (butterfly or slipper valve), always check the wiring and test the functions. This also applies to any additional components fitted, e.g. auxiliary switch or potentiometer.

Note Siemens slipper valves up to DN 50 can be commissioned without an actuator being fitted. In this case, the flow rate must be adjusted manually with the standard manual adjuster fitted to the valve.

Mode of operation



«AUTO» = automatic operation



«MAN» = manual operation

Direction of rotation

The actuators are factory-set to rotate in clockwise direction for opening (as seen from the cover).

Reversing the direction of rotation

The direction of rotation can be reversed by repositioning a connector located under the cover. The wiring for the OPEN and CLOSE control signal is not affected

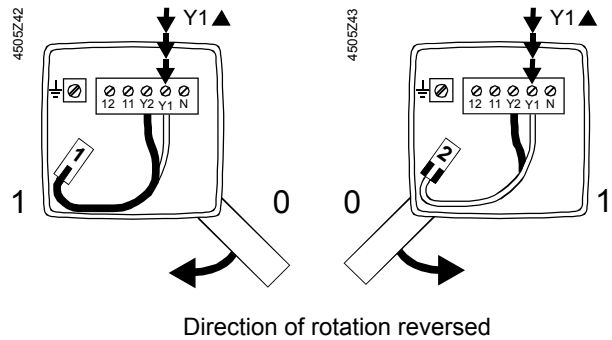

Setting the angle of rotation

The angle of rotation is factory-set to 90°. However, the angle can be changed to between 70° and 180°. This may be necessary when using non-Siemens valves. Special notes on this subject will be found in the mounting instructions for the ASK40 and ASK41.

Control

Every actuator must be driven by a dedicated controller (refer to «Connection diagrams»).

Maintenance

Caution

The actuators and butterfly valves require no maintenance.

Before performing any service work on the valve or actuator:

- Switch off the pump and power supply
- Close the main shut-off valves in the pipework
- Release pressure in the pipes and allow them to cool down completely

If necessary, disconnect electrical connections from terminals.

The butterfly or slipper valve must be re-commissioned only with the manual adjuster or the actuator correctly assembled.

Disposal



The actuator contains electrical and electronic components and must not be disposed of together with domestic waste.

Legislation may demand special handling of certain components, or it may be sensible from an ecological point of view.

Current local legislation must be observed.

Warranty

The technical data given for these applications is valid only in conjunction with the Siemens butterfly and slipper valves as detailed under «Equipment combinations» and with ASK40 / ASK41 mounting kits and valves of other manufacturers. The use of third-party valves other than those recommended by Siemens invalidates the warranty.

Technical data

		SQK33.00	SQL33.00	SQL33.03	SQL83.00
Power supply	Operating voltage	AC 230 V ±15 %			AC 24 V ±20 %
	Frequency	50 / 60 Hz			
	Power consumption ¹⁾	3 VA	4 VA	6.5 VA	4 VA
Control	Positioning signal	3-position			
	Parallel operation	parallel operation of several actuators not possible			
Operating data	Positioning time for 90°	at 50 Hz	125 s	30 s	125 s
		at 60 Hz	105 s	25 s	105 s
	Angle of rotation		90° ± 2° (factory setting)		
		adjustable	70°...180°		
	Torque ¹⁾	5 Nm	12.5 Nm	10 Nm	12.5 Nm
	End switch	Switching capacity AC 250 V, 6 A resistive, 2 A inductive Switching differential approx. 1°			
	Medium temperature	Permissible temperature of medium in the assembled valve: 120°C			
Standards	Meets the requirements for CE marking in	EMC directive 89/336/EEC Low-voltage directive 73/23/EEC			
	Electromagnetic compatibility	AC emissions: EN 61000-3-ff, EN 55014-1 and EN 55022 AC + DC immunity: EN 61000-4-ff			
	Product standards for automatic electrical controls	EN 60730-2-14			
	Housing protection standard	IP 44 to IEC 60529 / DIN 40050			
	Protection class	III or II to EN 60730			
Dimensions / weight	Dimensions	see «Dimensions»			
	Cable glands	4 x Ø 20.5 mm (for M20)			
	Weight	1.25 kg	1.35 kg	1.4 kg	1.35 kg
Materials	Housing base, yoke	die-cast aluminium			
	Cover	plastic			

¹⁾ These values apply at nominal voltage, at an ambient temperature of 20 °C and at the specified nominal running time

Accessories for SQK33.00, SQL33..., SQL83.00

			Weight
• Double auxiliary switch ASC9.5 / ASC9.4	Switching capacity	AC 250 V, 10 A resistive, 3 A inductive	ASC9.4 85 g
	Switching differential	approx. 1°	ASC9.5 30 g
• Auxiliary switch with potentiometer ASZ7.4	Switching capacity	AC 250 V, 10 A resistive, 3 A inductive	60 g
	Switching differential	approx. 1°	
	Change in resistance	0 ...1000 Ω corresponding to 0...90 °	

General ambient conditions

	Operation EN 60721-3-3	Transport EN 60721-3-2	Storage EN 60721-3-1
Environmental conditions	Class 3K5	Class 2K3	Class 1K3
Temperature	-15...+55 °C	-30...+65 °C	-15...+55 °C
Humidity	5...95 % r. h.	< 95 % r. h.	0...95 % r. h.

Internal diagrams

SQK33.00

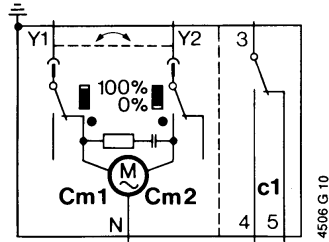

Cm1 End switch
Cm2 End switch
c1 1 auxiliary switch **ASC9.5**

SQL33.00

SQL33.03

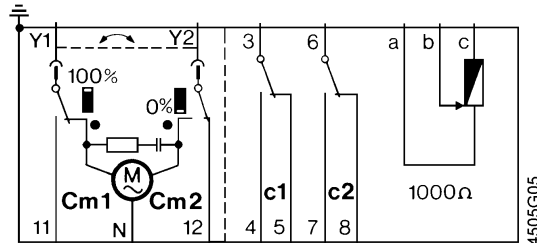

c1, c2 1 double auxiliary switch **ASC9.4**

c1, 1000 Ω 1 built-in unit **ASZ7.4**
(1 auxiliary switch and
1 potentiometer)

N Neutral conductor
G System potential
Y1 Control signal OPEN
Y2 Control signal CLOSED
11 Sequence Y1 at 90°
12 Sequence Y2 at 0°

SQL83.00

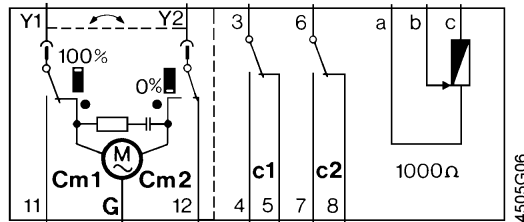

Connection diagrams

SQK33.00

SQL33...

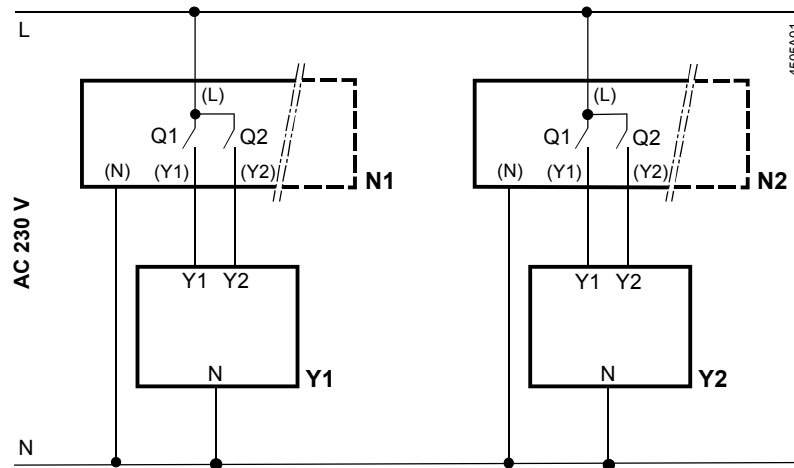

N1, N2 Controller
Y1, Y2 Actuator
L System potential AC 230 V
N System neutral
Q1, Q2 Controller contacts

SQL83.00

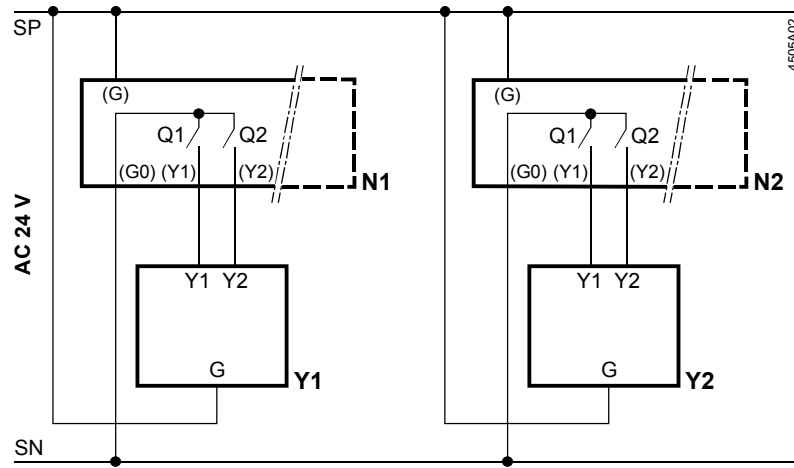

N1, N2 Controller
Y1, Y2 Actuator
 SP System potential AC 24 V
 SN System neutral
 Q1, Q2 Controller contacts

Dimensions

Dimensions in mm

SQK33.00

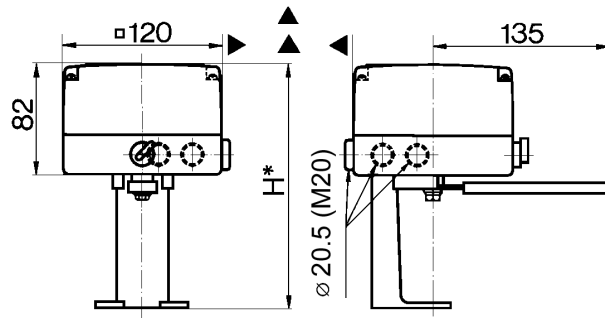

Installation height H*
 for actuator with mounting kit:
 ASK31 162 mm
 ASK32 132 mm
 ASK33 162 mm

**SQL33...
 SQL83.00**

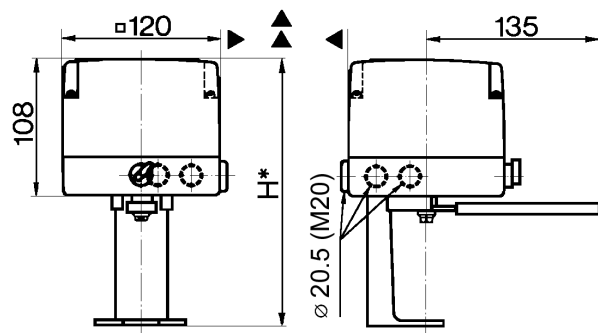

Installation height H*
 for actuator with mounting kit:
 ASK31 188 mm
 ASK32 158 mm
 ASK33 188 mm

Overall height of valve
 and actuator

= Installation height of slipper or butterfly valve from the middle of the pipe
 + Installation height H* of the actuator with mounting kit
 + Minimum clearance from ceiling or wall for mounting, connection,
 operation, service etc. ▶ >100 mm
 ▶▶ >200 mm