

Solenoid valves for gas VAS, Double solenoid valves VCS

Product brochure · GB
3.1.0.2 Edition 12.11



**krom
schroder**



- Safety shut-off valves for gas
- Suitable for a max. inlet pressure of 500 mbar (500 hPa/7 psig)
- Easy installation into a system
- Compact design saves space
- No extra valve required owing to integrated flow adjustment
- Check indication by blue LED
- Proof of closure switch with integral visual position indicator
- Suitable for high-duty cycling
- EC type-tested and certified
- FM, ANSI/CSA and AGA approved, UL listed
- Certified pursuant to GOST-TR
- VAS 1: certified for systems up to SIL 3 and PL e



valvario[®]



elster
Kromschroder

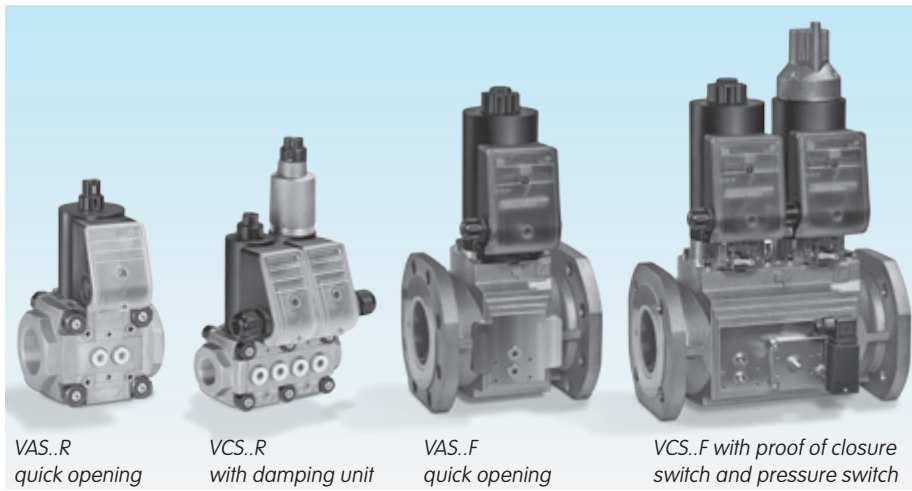

The modular design principle allows the individual components of the VAS, VCS Series to be easily assembled: e.g. quick opening, slow opening, with proof of closure switch and visual position indicator, slow opening with attached pressure switch.

Application

Solenoid valves for gas VAS and double solenoid valves VCS for safeguarding and controlling the air and gas supply to gas burners and gas appliances. For use in gas control and safety systems in all sectors of the iron, steel, glass and ceramics industries, also in commercial heat generation, such as the packaging, paper and foodstuffs industries.

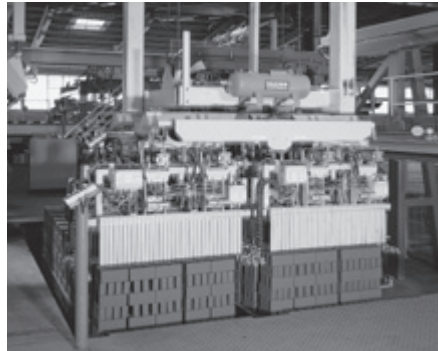

Ceramics industry



Aluminium industry:
curing oven for
wheel rims

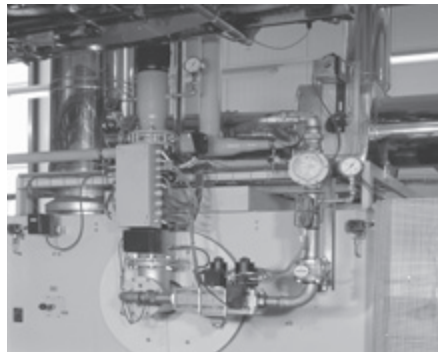

Foodstuffs industry:
baking oven

Examples of application

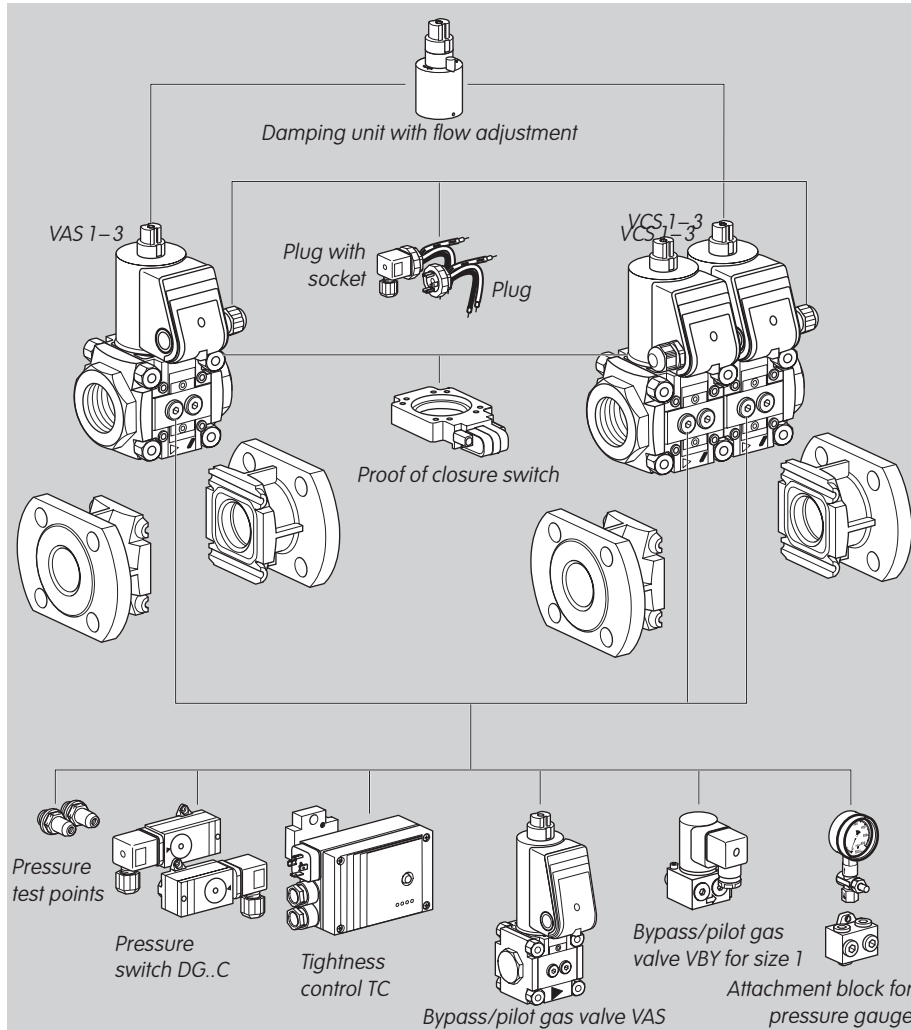

Solenoid valve for gas VAS 1-3,
Double solenoid valve VCS 1-3

Threaded flange for pipe connections from DN 10 to 65,
flanged connection for sizes 2 and 3 for pipe connections DN 40 and 50.

Modularly configurable with:

- Damping unit
- Proof of closure switch
- Plug (with or without socket)
- Pressure test points
- Pressure switch DG..C for inlet and/or outlet pressure
- Tightness control TC
- Bypass/pilot gas valve
- Attachment block for the connection of a pressure gauge, for example.

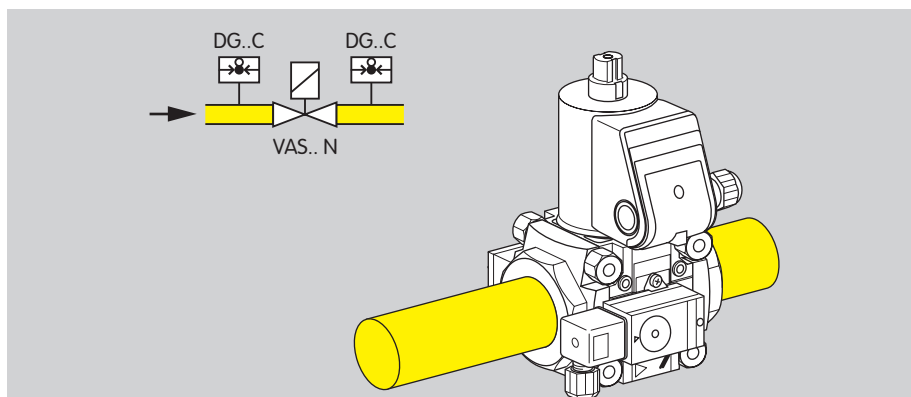

Gas solenoid valve with inlet and outlet pressure switch

VAS..N, quick opening,
pressure switch DG..C for inlet pressure p_u
and outlet pressure p_d

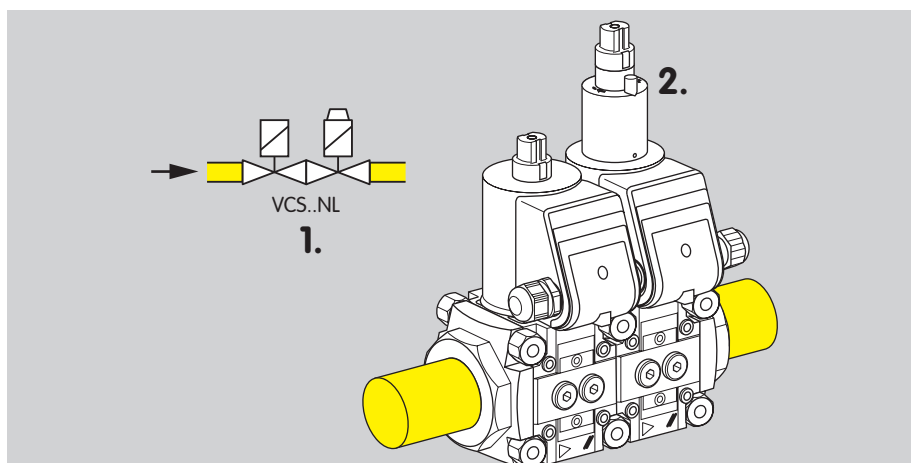

Double solenoid valve VCS with damping unit

VCS..NL,
1st valve: quick opening, quick closing, with flow adjustment
2nd valve: slow opening, quick closing

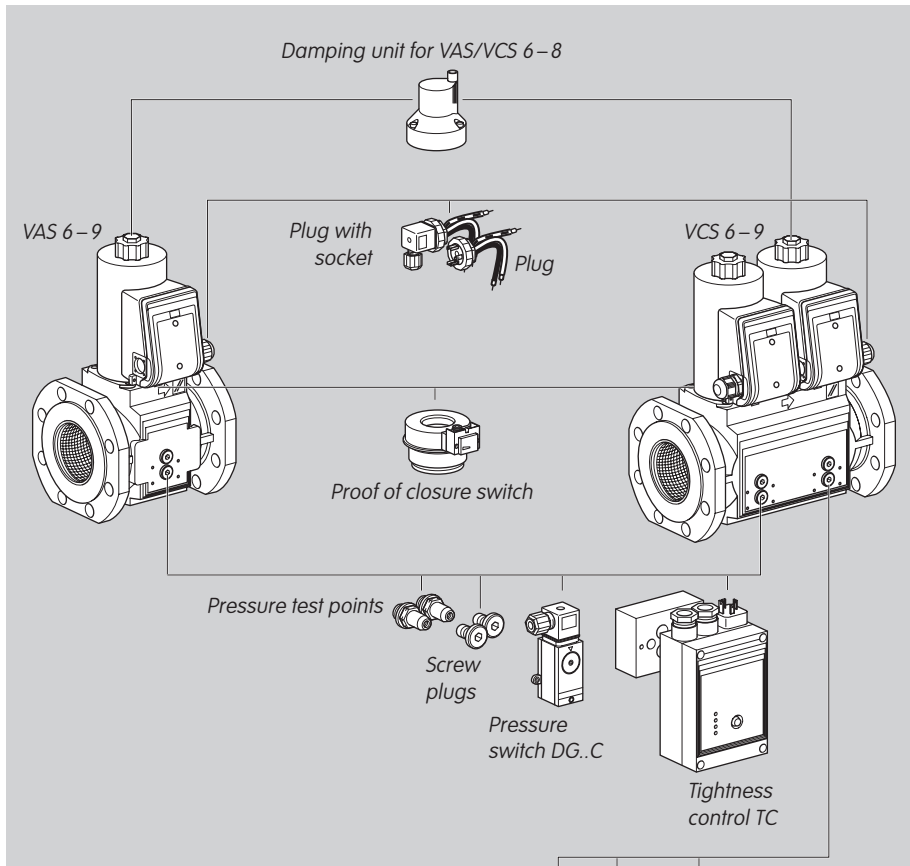

**Solenoid valve for gas VAS 6-9,
Double solenoid valve VCS 6-9**

Gas solenoid valve and double solenoid valve with flanged connection (ISO or ANSI) for pipe connections from DN 65 to 125.

Modularly configurable with:

- Damping unit for VAS/VCS 6-8
- Proof of closure switch
- Plug
- Plug with socket

VCS 6-9 with threaded connections for:

- Screw plugs
- Pressure test points
- Pressure switch DG..C for inlet/inter-space pressure
- Tightness control TC

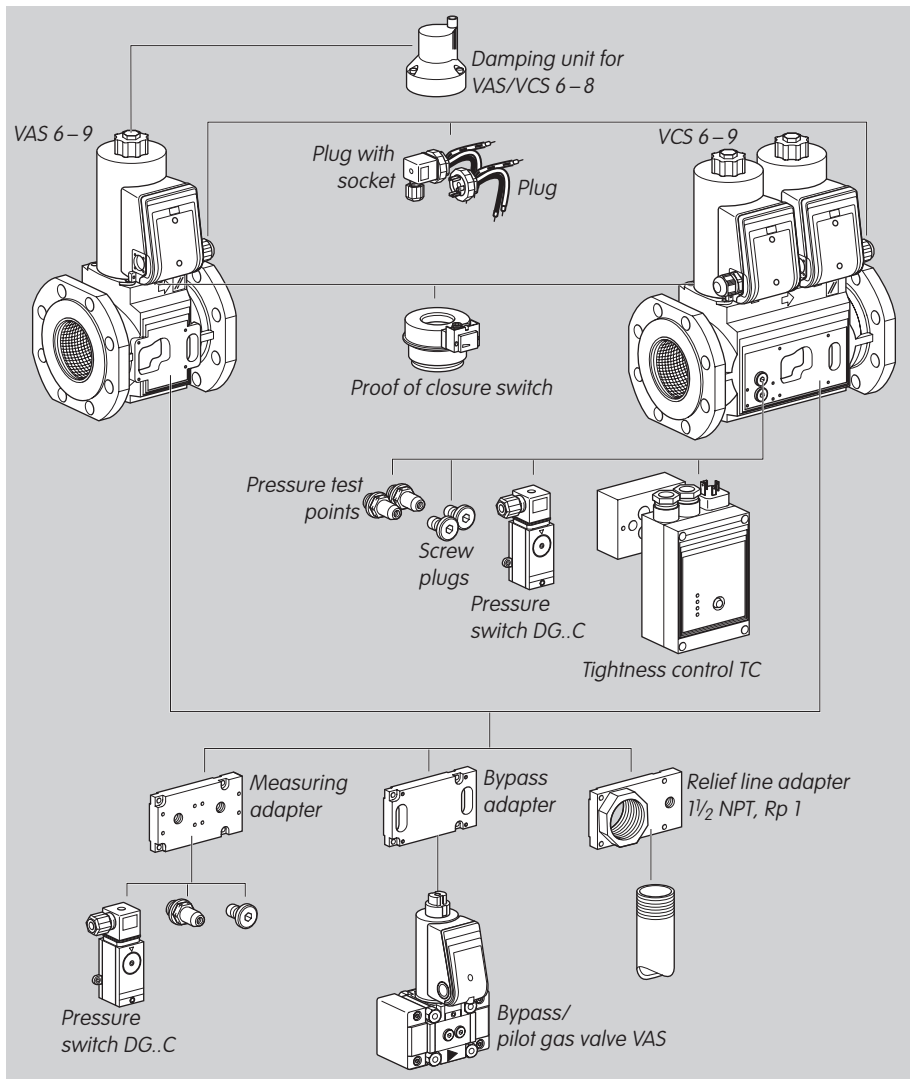

**Solenoid valve for gas VAS 6-9,
Double solenoid valve VCS 6-9 with
connection for adapter plates**

Gas solenoid valve and double solenoid valve with flanged connection (ISO or ANSI) for pipe connections from DN 65 to 125.

Modularly configurable with:

- Damping unit for VAS/VCS 6-8
- Proof of closure switch
- Plug
- Plug with socket

With adapter plates, expandable with:

- Pressure switch DG..C
VAS 6-9: for inlet/outlet pressure
VCS 6-9: for interspace/outlet pressure
- Pressure test points
- Screw plug
- Bypass or pilot gas valve VAS

VCS 6-9

With two threaded connections for:

- Screw plugs
- Pressure test points
- Pressure switch DG..C for inlet/inter-space pressure
- Tightness control TC

Expandable with relief line adapter (1 1/2 NPT, Rp 1) for relief line.

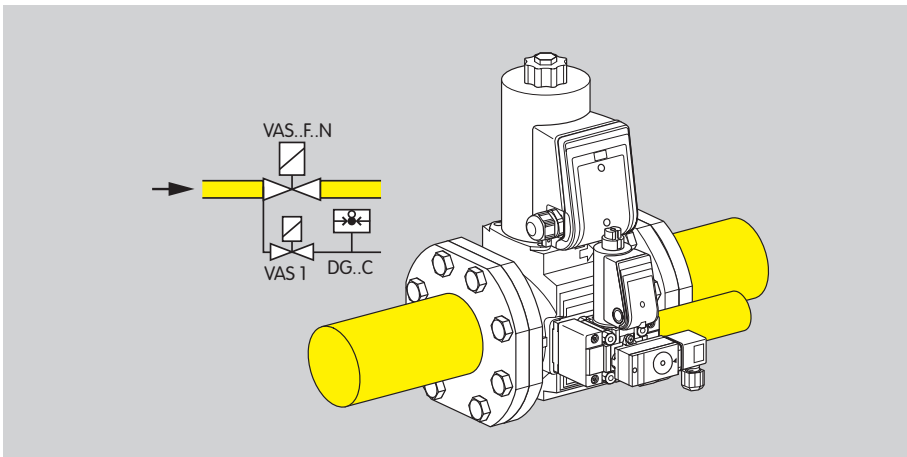

Gas solenoid valve with pilot gas valve and pressure switch

VAS..F.N: quick opening, quick closing, VAS 1 as pilot gas valve with pressure switch DG..C

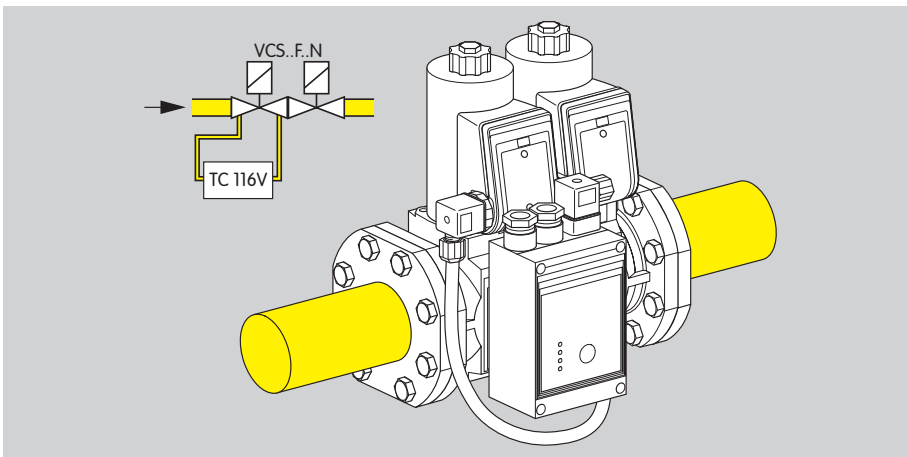

Double solenoid valve with tightness control

VCS..F.N: quick opening, quick closing valves, tightness control TC 116V

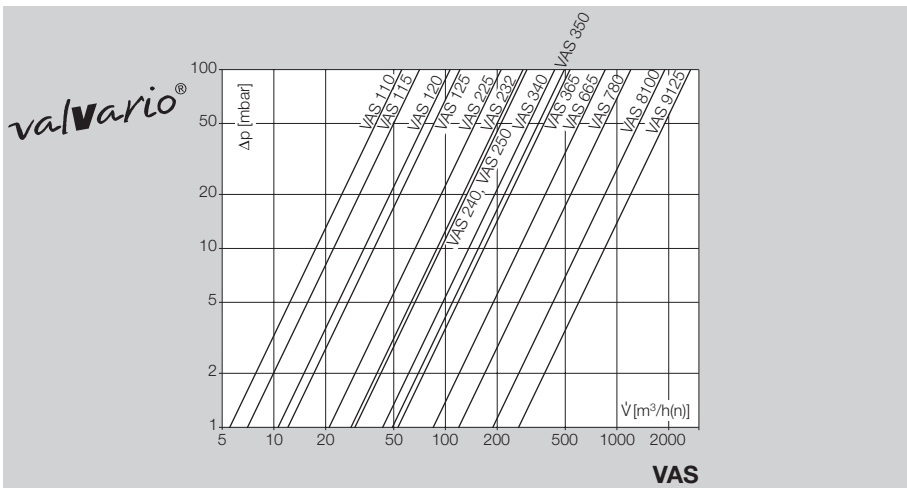

Flow rate VAS

Gas type: natural gas

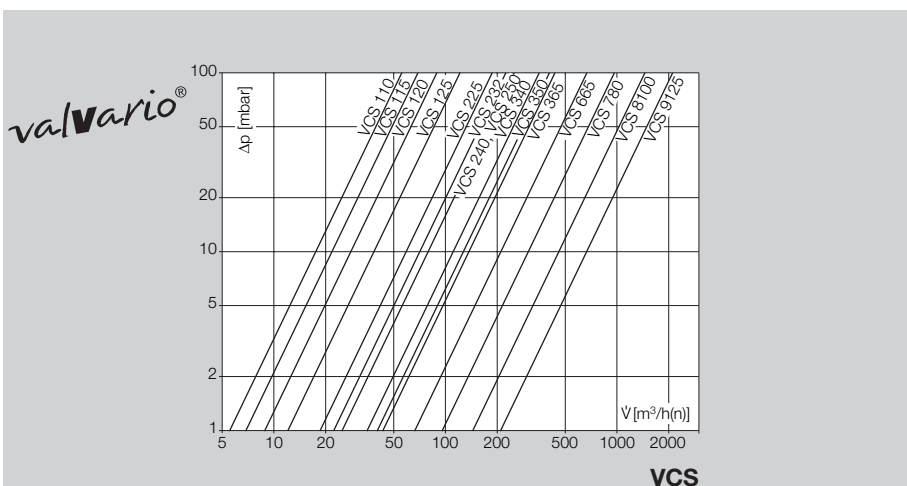

Flow rate VCS

Gas type: natural gas

Replacement possibilities

Solenoid valve for gas VG is to be replaced by VAS.

Type code VAS 1–3

Code	Description
VAS	Gas solenoid valve
1–3	Size
T	T-product
–	Without inlet and outlet flange
-0	Blind flange
10, 15, 20, 25, 32, 40, 50, 65	Nominal inlet and outlet diameter
R	Rp internal thread
N	NPT internal thread
F	ISO flange
/N	Quick opening, quick closing
/L	Slow opening, quick closing
K	Mains voltage 24 V DC
P	Mains voltage 100 V AC; 50/60 Hz
Q	Mains voltage 120 V AC; 50/60 Hz
Y	Mains voltage 200 V AC; 50/60 Hz
W	Mains voltage 230 V AC; 50/60 Hz
S	Proof of closure switch with visual position indicator
G	Proof of closure switch for 24 V with visual position indicator
R	Viewed from the right (in the direction of flow)
L	Viewed from the left (in the direction of flow)

Type code VAS 6–9

Code	Description
VAS	Gas solenoid valve
6–9	Size
T	T-product
65, 80, 100, 125	Nominal inlet flange diameter
F	ISO flange
A	ANSI flange
05	Max. inlet pressure $p_{U \max}$ 500 mbar (500 hPa/7 psig)
/N	Quick opening, quick closing
/L	Slow opening, quick closing
K	Mains voltage 24 V DC
Q	Mains voltage 120 V AC; 50/60 Hz
W	Mains voltage 230 V AC; 50/60 Hz
A	Mains voltage 120–230 V AC; 50/60 Hz
S	Proof of closure switch with visual position indicator
G	Proof of closure switch for 24 V with visual position indicator
R	Viewed from the right (in the direction of flow)
L	Viewed from the left (in the direction of flow)
3	Electrical connection: M20 cable gland
P	2 screw plugs, at the top, at the inlet and outlet
M	2 pressure test points, at the top, at the inlet and outlet
Accessories, right, inlet	
/P	Screw plug
/M	Pressure test point for inlet pressure p_U
/1	Gas pressure switch DG 17VC
/2	Gas pressure switch DG 40VC
/3	Gas pressure switch DG 110VC
/4	Gas pressure switch DG 300VC
/B	Bypass valve VAS 1, fitted
/Z	Pilot gas valve VAS 1, fitted
/V	Prepared for breather line 1½ NPT
/E	Prepared for breather line Rp 1
Accessories, right, outlet	
P	Screw plug
M	Pressure test point for outlet pressure p_d
1	Gas pressure switch DG 17VC
2	Gas pressure switch DG 40VC
3	Gas pressure switch DG 110VC
4	Gas pressure switch DG 300VC
-	No accessories
Accessories, left, inlet	
/P	Screw plug
/M	Pressure test point for inlet pressure p_U
/1	Gas pressure switch DG 17VC
/2	Gas pressure switch DG 40VC
/3	Gas pressure switch DG 110VC
/4	Gas pressure switch DG 300VC
/B	Bypass valve VAS 1, fitted
/Z	Pilot gas valve VAS 1, fitted
/V	Prepared for breather line 1½ NPT
/E	Prepared for breather line Rp 1
Accessories, left, outlet	
P	Screw plug
M	Pressure test point for outlet pressure p_d
1	Gas pressure switch DG 17VC
2	Gas pressure switch DG 40VC
3	Gas pressure switch DG 110VC
4	Gas pressure switch DG 300VC
-	No accessories

Type code VCS 1–3

Code	Description
VCS	Gas solenoid valve
1–3	Size
T	T-product
–	Without inlet and outlet flange
10, 15, 20, 25, 32, 40, 50, 65	Nominal inlet and outlet diameter
R	Rp internal thread
N	NPT internal thread
F	ISO flange
N	1 st valve quick opening, quick closing
L	1 st valve slow opening, quick closing
N	2 nd valve quick opening, quick closing
L	2 nd valve slow opening, quick closing
K	Mains voltage 24 V DC
P	Mains voltage 100 V AC; 50/60 Hz
Q	Mains voltage 120 V AC; 50/60 Hz
Y	Mains voltage 200 V AC; 50/60 Hz
W	Mains voltage 230 V AC; 50/60 Hz
S	Proof of closure switch with visual position indicator
G	Proof of closure switch for 24 V with visual position indicator
R	Viewed from the right (in the direction of flow)
L	Viewed from the left (in the direction of flow)

Type code VCS 6–9

Code	Description
VCS	Gas solenoid valve
6–9	Size
T	T-product
65, 80, 100, 125	Nominal inlet flange diameter
F	ISO flange
A	ANSI flange
05	Max. inlet pressure $p_{e,max}$ 500 mbar (500 hPa/7 psig)
N	1 st valve quick opening, quick closing
L	1 st valve slow opening, quick closing
N	2 nd valve quick opening, quick closing
L	2 nd valve slow opening, quick closing
K	Mains voltage 24 V DC
Q	Mains voltage 120 V AC~; 50/60 Hz
W	Mains voltage 230 V AC~; 50/60 Hz
A	Mains voltage 120–230 V AC~; 50/60 Hz
S	Proof of closure switch with visual position indicator
G	Proof of closure switch for 24 V with visual position indicator
R	Viewed from the right (in the direction of flow)
L	Viewed from the left (in the direction of flow)
3	Electrical connection: M20 cable gland
P	2 screw plugs, at the top, at the inlet and outlet
M	2 pressure test points, at the top, at the inlet and outlet

Accessories, right, inlet

/P	Screw plug
/M	Pressure test point for inlet pressure p_U
/1	Gas pressure switch DG 17VC
/2	Gas pressure switch DG 40VC
/3	Gas pressure switch DG 110VC
/4	Gas pressure switch DG 300VC

Accessories, right, interspace 1

P	Screw plug
M	Test point for interspace pressure p_Z
1	Gas pressure switch DG 17VC
2	Gas pressure switch DG 40VC
3	Gas pressure switch DG 110VC
4	Gas pressure switch DG 300VC

Accessories, right, interspace 2

P	Screw plug
M	Test point for interspace pressure p_Z
1	Gas pressure switch DG 17VC
2	Gas pressure switch DG 40VC
3	Gas pressure switch DG 110VC
4	Gas pressure switch DG 300VC
B	Bypass valve VAS 1, fitted
Z	Pilot gas valve VAS 1, fitted
V	Prepared for breather line 1½ NPT
E	Prepared for breather line Rp 1
-	No accessories

Accessories, right, outlet

P	Screw plug
M	Pressure test point for outlet pressure p_D
1	Gas pressure switch DG 17VC
2	Gas pressure switch DG 40VC
3	Gas pressure switch DG 110VC
4	Gas pressure switch DG 300VC
-	No accessories

The same accessories can be selected for the left- or right-hand side.

Technical data

Gas types: natural gas, LPG (gaseous), biologically produced methane (max. 0.1 %-by-vol. H₂S) or clean air; other gases on request. The gas must be dry in all temperature conditions and must not contain condensate.

CE and FM approved, UL listed, max. inlet pressure p_U : 500 mbar (500 hPa/7 psig).

FM approved, non operational pressure: 700 mbar (700 hPa/10 psig).

ANSI/CSA approved: 350 mbar (350 hPa/5 psig).

Flow adjustment limits the maximum flow volume between approx. 20 and 100%. On VAS 1–3, the setting can be monitored on an indicator.

Adjustment of the start gas rate: 0 to approx. 70%.

Opening times:
VAS../N quick opening: ≤ 1 s;
VAS../L slow opening: up to 10 s.

Closing time:
VAS../N, VAS../L quick closing: < 1 s.

Ambient temperature:
-20 to +60°C (-4 to +140°F),
no condensation permitted.

Storage temperature:
-20 to +40 °C (-4 to +104°F),
no condensation permitted.

Safety valve:
Class A Group 2 pursuant to EN 13611 and EN 161,
Factory Mutual (FM) Research Class: 7410 and 7411,
ANSI Z21.21 and CSA 6.5.

Mains voltage:
230 V AC, +10/-15%, 50/60 Hz,
200 V AC, +10/-15%, 50/60 Hz,
120 V AC, +10/-15%, 50/60 Hz,
100 V AC, +10/-15%, 50/60 Hz,
24 V DC, $\pm 20\%$.

Cable gland: M20 x 1.5.

Electrical connection: cable with max. 2.5 mm² (AWG 12) or plug with socket to EN 175301-803.

Enclosure: IP 65.

Duty cycle: 100%.

Power factor of the solenoid coil: $\cos \varphi = 1$.

Switching frequency:
VAS../N: arbitrary,
VAS../L: there must be a period of 20 seconds between switching off and on again so that the damping is fully effective.

Valve housing: aluminium,
valve seal: NBR.

Connection flanges:
VAS/VCS 1–3 with internal thread:
Rp pursuant to ISO 7-1, NPT pursuant to ANSI/ASME;
VAS/VCS 6–9 with ISO flange (pursuant to ISO 7005) PN 16,
with ANSI flange pursuant to ASA.

VAS/VCS 9

Mains voltage:
120–230 V AC, +10/-15%, 50/60 Hz.

Switching frequency: max. 1 x per minute.

Max. temperature of solenoid coil:
+20°C (+68°F) above ambient temperature.

Current consumption at 20°C (68°F):
pick-up current: 1.8 A,
holding current: 0.3 A.

Maintenance cycles

At least once per annum, at least twice per annum for biologically produced methane.

If the flow rate drops, clean the strainer!

Detailed information on this product

www.docuthek.com → Elster Kromschroeder

Search term: VAS, VCS

Kind of document: Technical information

Contact

www.kromschroeder.com → Sales

Elster GmbH
Postfach 2809 · 49018 Osnabrück
Strothweg 1 · 49504 Lotte (Büren)
Germany

T +49 541 1214-0
F +49 541 1214-370
info@kromschroeder.com
www.kromschroeder.com
www.elster.com

We reserve the right to make technical modifications in the interests of progress.

Copyright © 2011 Elster Group
All rights reserved.