

## RA-3000 Electric Actuator

### **I**ntrouction

The RA-3000 series synchronous motor-driven reversible actuators are available for 3-point (floating) or with electric positioner for 0...10 V control. They feature factory calibrated pressure switches to provide specified close-off ratings.

These actuators are available in three sizes with 1600 N, 1800 N and with 3000 N nominal force and can be used with JC flanged valves according to maximum close-off pressure ratings specified.

Factory fitted options, such as 2k $\Omega$  feedback potentiometer, auxiliary switches and hand crank are available.



**RA-3000 Actuator with VG8000N valve**

### Features and Benefits

<input type="checkbox"/> <b>Uses synchronous motor with pressure switches</b>	Fixed close-off force Constant running time
<input type="checkbox"/> <b>Special clamp coupler quick-fit system</b>	Provides quick and easy mounting of the actuator on valves with slotted stem. Cuts installation costs.
<input type="checkbox"/> <b>Models for 3-point and proportional 0...10 VDC control</b>	Allows optimum choice of control signal
<input type="checkbox"/> <b>Positioner with adjustable starting point, span, and direct/reverse action</b>	Provides flexibility in application Allows easy sequencing from only one output signal
<input type="checkbox"/> <b>Active 0...10 VDC position feedback on proportional models</b>	Provides active signal for independent position monitoring
<input type="checkbox"/> <b>Optional auxiliary switches and feedback potentiometer available</b>	Provides potential free contacts for independent monitoring of the actuator's position
<input type="checkbox"/> <b>Optional hand crank</b>	Allows manual positioning independent of power supply

## Ordering data

RA-3   -7

### Actuator Force and Supply voltage\*)

<b>126</b>	1600 N	24 V, 50/60 Hz
<b>127</b>	1600 N	230 V, 50/60 Hz
<b>226</b>	1800 N	24 V, 50/60 Hz
<b>227</b>	1800 N	230 V, 50/60 Hz
<b>325</b>	3000 N	24 V, 60 Hz
<b>326</b>	3000 N	24 V, 50 Hz
<b>327</b>	3000 N	230 V, 50 Hz
<b>328</b>	3000 N	230 V, 60 Hz

### Accessories, factory mounted

<b>00</b>	None
<b>03</b>	Two auxiliary switches and 2 k $\Omega$ feedback potentiometer
<b>05</b>	Two auxiliary switches and 135 $\Omega$ feedback potentiometer
<b>41</b>	Built-in electronic Positioner 0...10 VDC and two auxiliary Switches (only 24 VAC models)

### Hand crank

<b>0</b>	None
<b>1</b>	With hand crank

\*) For other supply voltage and frequency, please contact your Johnson Controls supplier.

## Ordering Procedure

The valves and actuators can be ordered separately or factory mounted. When factory mounted, please add "+M" behind the order code for the actuator.

### For example:

For a 2-way valve, DN 65,  $k_{VS}$  63, PN 16 plus actuator with electric positioner 0...10 V input, 24 VAC / 50 Hz supply, order:

Item 1 **VG82G1S1N** (valve body)  
 Item 2 **RA-3041-7326** (actuator)

Alternatively, if actuator is requested to be factory mounted, order:

Item 1 **VG82G1S1N** (valve body)  
 Item 2 **RA-3041-7326+M** (actuator)

## Accessory Kits for field mounting

<b>EQ-5687-7011</b>	Two Auxiliary Switches and Feedback Potentiometer 2 k $\Omega$
<b>282 3501 114</b>	Cable conduit adapter PG 13.5 ( $\varnothing$ 7...11mm) DIN 46320 - FS

## Repair parts

<b>EG-0572-7041</b>	Electronic Positioner EPOS 4 plug-in module for field replacement
---------------------	---

## Actuator - Valve combinations

The RA-3000 electric actuators are specifically designed to be used in conjunction with the VBB, VBD, VBF and VG8000N valve series. The ordering data for these valve bodies are as follows:

- **VBB series** (PN 16 and 25 pressure balanced flanged valves)

**2-way PDTC**      **DN 50...150**

- **VBD series** (PN 25 flanged valves)

**2-way PDTC**      **DN 15...150**

**3-way mixing**      **DN 15...150**

- **VBF series** (PN 6 & PN 10 flanged valves)

**2-way PDTO**      **DN 65...100**

**3-way mixing**      **DN 65...100**

- **VG8000N series** (PN16 flanged valves)

**2-way PDTC**      **DN 15...150**

**2-way PDTO**      **DN 15...40**

**3-way mixing**      **DN 15...150**

**3-way diverting**      **DN 15...150**

- **VG8000V series** (PN16 flanged valves Max fluid temperature 140°C)

**2-way PDTC**      **DN 15...150**

**3-way mixing**      **DN 15...150**

- **VG9000 series** (PN 6 & PN 10 flanged valves)

**2-way PDTO**      **DN 80 & 100**

**3-way mixing**      **DN 80 & 100**

Please refer to the relevant flanged valve product bulletins for complete ordering information.

# Operation

## 3-point models

Connections	Actuator Stem
1-2	extends
1-3	retracts

## Proportional models

Action Jumper	Input control signal	Actuator Stem
Direct acting (DA)	increases decreases	retracts extends
Reverse acting (RA)	increases decreases	extends retracts

# Mounting instructions

When mounting the actuator on a valve, please follow the instructions below:

- It is recommended that the valves be mounted in the upright position in a conveniently accessible location. When mounted horizontally, the yoke should be fitted such that the stanchions are positioned vertically one above the other.

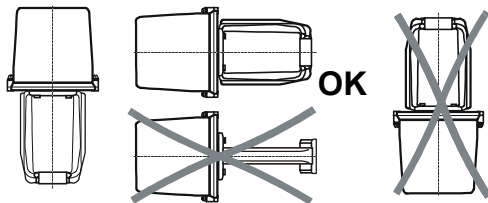

- The actuator must be protected against dripping water, which could enter the housing and damage the mechanism or motor.
- The actuator must not be covered with insulating material
- Sufficient clearance must be allowed for actuator removal (refer to the dimension drawings)
- The valve must be fitted so that the plug seats against the flow as indicated by the arrow(s) on the valve body.

# Wiring instructions

- All wiring must be in accordance with local regulations and national electrical codes, and should be carried out by authorised personnel only.
- Make sure that the line power supply is in accordance with the power supply specified on the device.
- See also the instructions in paragraph "Application".

## ⚠ WARNING

### Shock Hazard

Disconnect the power supply before wiring connections are made to avoid personal injury.

### Equipment Damage Hazard

Make and check all wiring connections before applying power to the system. Short circuited or improperly connected wires may result in permanent damage to the unit

## Wiring diagrams

### 3-point models

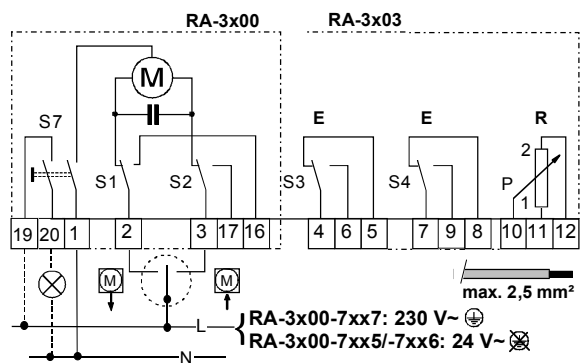

### Proportional models

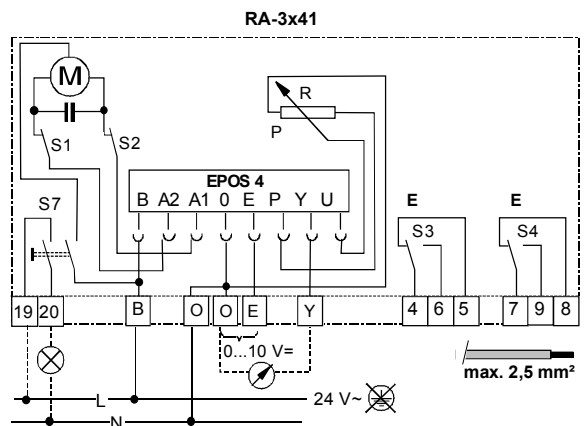

# Adjustments

## **⚠ WARNING**

### **Shock Hazard**

The utmost care must be taken when the cover is removed (by authorised personnel only) for adjustment or inspection.

In all other cases when the cover is removed the power must be switched off.

Do not touch or attempt to connect or disconnect wires when the electrical power is on.

### **Switch S7**

The electrical supply can be switched off manually by pressing the red button on the underside of the motor unit housing. When power is off it protrudes 5 mm, with power on, it protrudes 2 mm.

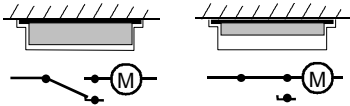

**Hand crank (optional)** enables manual positioning of the valve. The power supply should be switched off by means of switch S7 before the hand crank is used.

### **Actuators with 0...10 V DC Positioner**

Models with built-in electronic positioner have a 0...10 V input. The starting point, the span and the D.A. or R.A. (Direct or Reverse Action) mode can be adjusted on the positioner.

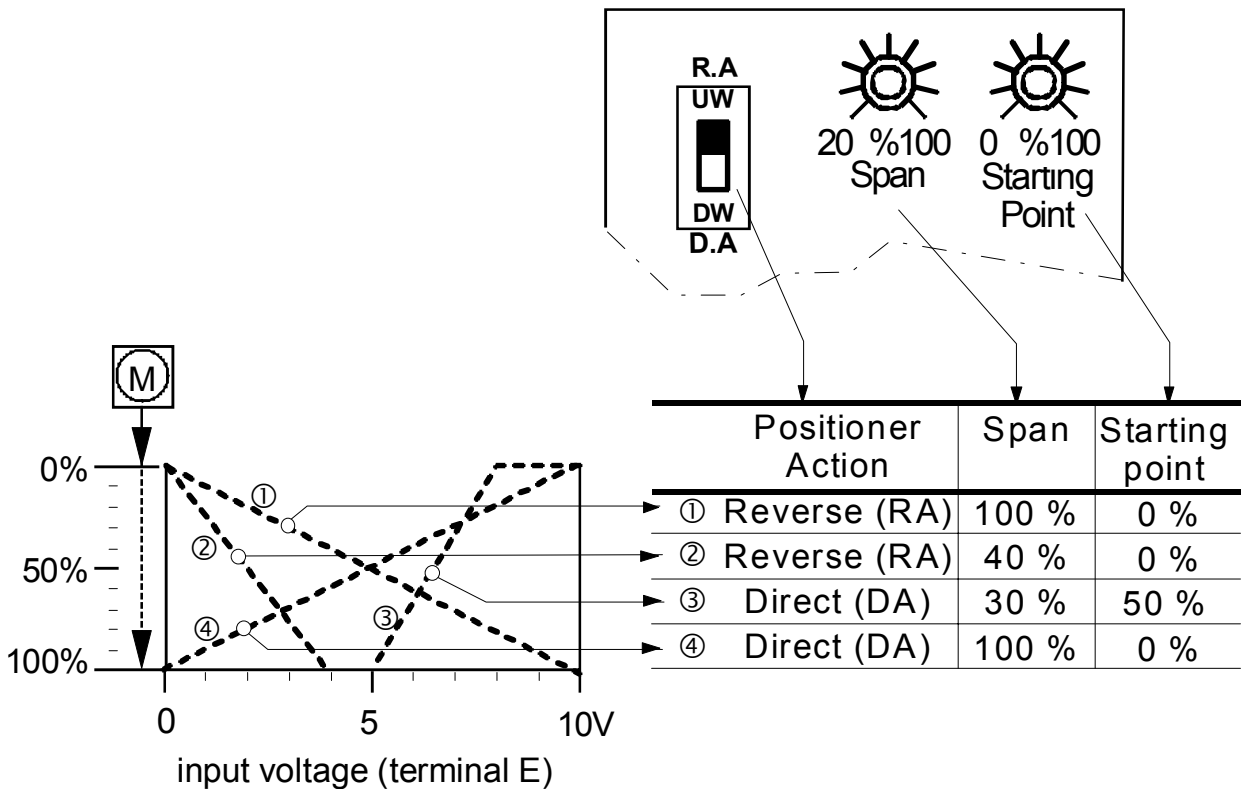

# Applications

Parallel and sequenced operation of actuators

**CAUTION**  
 Parallel connection is only possible using isolation relays. If the parallel running motors do not have separately switched power supplies one or more motors will start to cycle at the end of travel.

## Actuators (24V only) with built-in positioner for controllers with 0...10V output

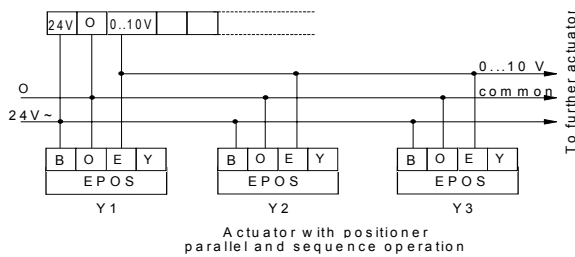

The controller output 0...10 V can operate several actuators with built-in electronic positioner EPOS. The electrical wiring for parallel and sequenced operation is identical. The sequencing and action of the actuator are individually adjustable on each positioner. Each positioner has its own adjustment for starting point between 0...10 V (0...100 %) and span between 2...10 V (20...100 %). Using the minimum adjustable span of 20 % therefore enables a maximum of 5 sequenced devices; further sequencing can be accomplished by using additional controller outputs. Each positioner can be switched for direct or reverse action.

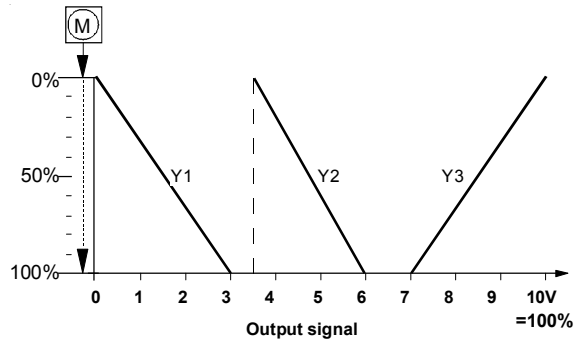

Adjustments for Y1, Y2, Y3 (example):

	starting point	span	positioner action
Y1	0 %	30 %	reverse acting
Y2	35 %	25 %	reverse acting
Y3	70 %	30 %	direct acting

## Reversible actuator without positioner for incremental controller

### Sequencing two actuators without positioner using limit switches

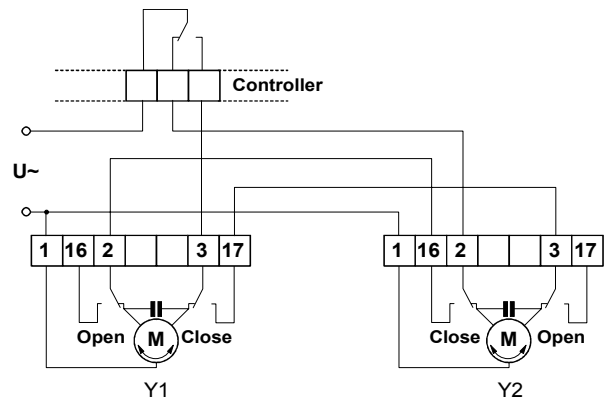

## Parallel operation of actuators without positioner with synchronous motor, condenser and limit switches

Although synchronous motors have the same running speed (rate of travel) deviation in travel between motors can accumulate during starts and stops because of varying load. This deviation depends on the number of on/off cycles and is about 0.5 % per 100 cycles. By periodical switching of the actuators to end of travel (e.g. normal position) parallel-operated actuators can run reasonably synchronous.

## Dimensions in mm

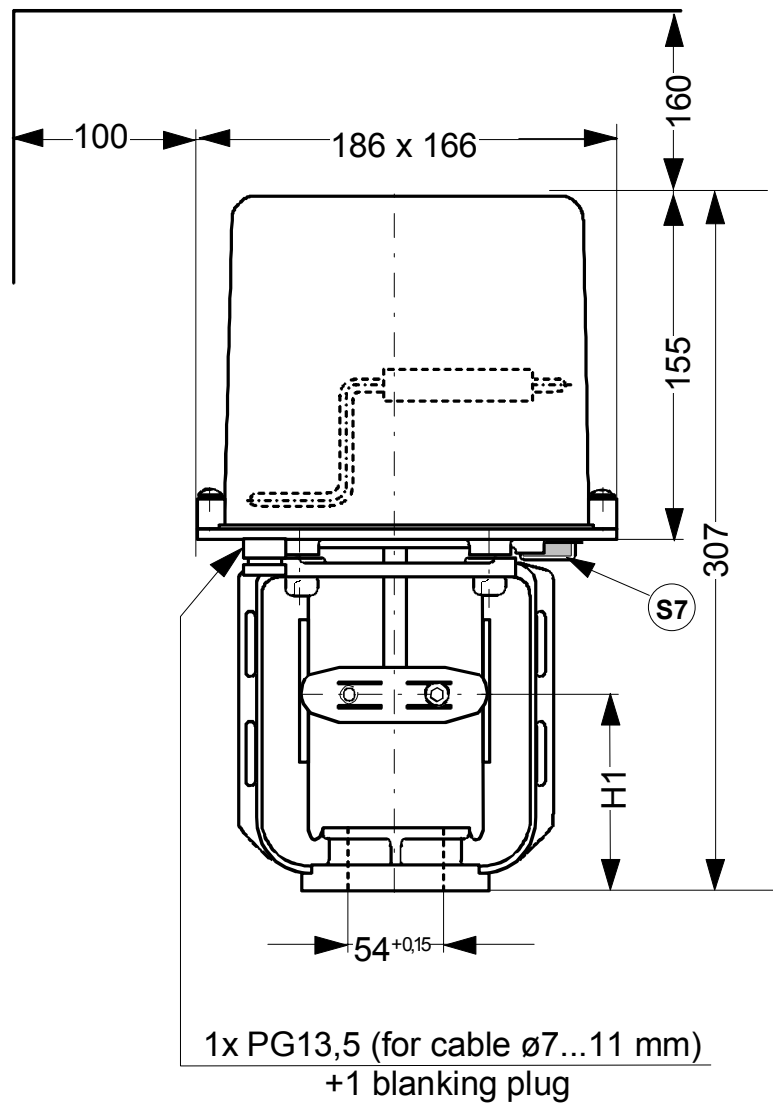

	RA-3xxx -712x	RA-3xxx -722x	RA-3xxx -732x
H1	58 mm	66 mm	66 mm

**N**otes:

## Specifications

Actuator models		RA-3xxx-....						
		-712x		-722x		-732x		
<b>Associated valve series and body sizes</b>		VBB	DN 50	65	VBB	DN 80	150	
	VBD	DN 15...40	VBD	DN 50	65	VBD	DN 50	150
			VBF	DN 65...100	VBF	DN 65...100		
	VG8000N	DN 15...40	VG8000N	DN 50...80	VG8000N	DN 50...150		
	VG8000V	DN 15...40	VG8000V	DN 50...80	VG8000V	DN 50...150		
		VG9000	DN 80 & 100	VG9000	DN 80 & 100			
<b>Type of motor</b>		Synchronous, Reversible						
<b>Action / Control</b>		<ul style="list-style-type: none"> <li>3-point</li> <li>3-point with 5(3) A / 250 VAC auxiliary switches and 2k<math>\Omega</math> or 135<math>\Omega</math> feedback potentiometer</li> <li>Proportional with built-in 0...10 V electronic positioner (input impedance 5.6 k<math>\Omega</math>) and with 5(3) A / 250 VAC auxiliary switches</li> </ul>						
<b>Hand crank</b>		Optional						
<b>Supply voltage and frequency*)</b>	24 VAC $\pm$ 10%, 50/60 Hz 230 VAC $\pm$ 10%, 50/60 Hz	24 VAC $\pm$ 10%, 50/60 Hz 230 VAC $\pm$ 10%, 50/60 Hz	24 VAC $\pm$ 10%, 50/60 Hz 230 VAC $\pm$ 10%, 50/60 Hz	24 VAC $\pm$ 10%, 50/60 Hz 230 VAC $\pm$ 10%, 50/60 Hz	24 VAC $\pm$ 10%, 50/60 Hz 230 VAC $\pm$ 10%, 50/60 Hz	24 VAC $\pm$ 10%, 50/60 Hz 230 VAC $\pm$ 10%, 50/60 Hz	24 VAC $\pm$ 10%, 50/60 Hz 230 VAC $\pm$ 10%, 50/60 Hz	
<b>Power consumption (with positioner)</b>	7 VA (9 VA)	10 VA (12 VA)	10 VA (12 VA)	10 VA (12 VA)	16 VA (18 VA)	16 VA (18 VA)	16 VA (18 VA)	
<b>Nominal force</b>	1600 N	1800 N	1800 N	1800 N	3000 N	3000 N	3000 N	
<b>Nominal stroke</b>	13 mm	25 mm	25 mm	25 mm	42 mm	42 mm	42 mm	
<b>Nominal running speed at 50 (60) Hz</b>	6.24 ( 5.20 ) s/mm	4.16 ( 3.48 ) s/mm	4.16 ( 3.48 ) s/mm	4.16 ( 3.48 ) s/mm	4.4 ( 3.67 ) s/mm	4.4 ( 3.67 ) s/mm	4.4 ( 3.67 ) s/mm	
<b>Enclosure Protection</b>		IP 54						
<b>Materials:</b>								
<b>Stem</b>		Stainless steel (DIN Mat. spec. No. 1.4305 )						
<b>Motor unit housing and Yoke</b>		Die cast aluminium						
<b>Operation and Storage Conditions</b>		-10...+60 °C (-10...+50 °C with electronic positioner) R.H. 10...90 %, non condensing						
<b>Electrical Connection</b>		Threaded connector 2.5 mm <sup>2</sup>						
<b>Conduit adapter</b>		1 x PG 13.5 +1 blanking plug						
<b>Net weight</b>	4 kg	4 kg	4 kg	4 kg	4.4 kg	4.4 kg	4.4 kg	
<b>Approvals</b>		European Directives: EMC (89 / 336 / EEC) LVD (73 / 23 / EEC)						

\*) For other supply voltage and frequency, please contact your Johnson Controls supplier.

The performance specifications are nominal and conform to acceptable industry standards. For application at conditions beyond these specifications, consult the local Johnson Controls office. Johnson Controls, Inc. are not liable for damages resulting from misapplication or misuse of its products.

Johnson Controls International, Inc.  
 Headquarters: Milwaukee, WI, USA  
 European headquarters: Westendhof 8, 45143 Essen, Germany  
 European Factories: Essen (Germany), Leeuwarden (The Netherlands), Lomagna (Italy).  
 Branch Offices: principal European Cities

Printed in Germany