

# Series 700 Pressure & Differential Pressure Switch

for Potentially Explosive Atmospheres



Data sheet : S700DP\_EX/2012

The Series 700 Pressure and Differential Pressure switches offer accurate, reliable switching in a robust cast enclosure.

- Exd, ExnC, ExtD, Exia, I.S.
- RANGES FROM 16 mBAR TO 600 BAR
- HIGH OVERLOAD RATINGS
- SIMPLE MAINTENANCE
- SAFETY VENT RING

These switches provide excellent repeatability and long in-service life, under both continuous cycling and overload conditions, due to the mechanical restriction of diaphragm travel.

A standard feature of the design is the inclusion of a venting and isolation chamber which (in the unlikely event of the process diaphragm failure) will prevent the process entering the switching enclosure.

The setpoint of the switch is adjusted by means of a capstan head screw, located within the lower section of the enclosure. This enables adjustment to be made even when energised, as it does not violate the flameproof integrity of the enclosure.

With over 50 pressure and DP ranges and a wide selection of output switches, diaphragm and pressure chamber materials, and process connections (including flanges), Series 700 switches meet the requirements of a wide range of applications. In addition HNL can offer many non-standard options (see back page for details) or customise this product to meet your unique requirements.

Rototherm Series 700 switches can provide many years of maintenance free operation. All models are serviceable and spares, including diaphragm kits and output switch kits are readily available. Drawings and technical data sheets are supplied as standard.

Our extensive stockholding of components and the modular design allows this product to be supplied rapidly to meet customers delivery requirements.



Exd SWITCHES (Cert: Baseefa07ATEX0055X)

Enclosures are certified Exd IIC T4/T5/T6 to EN 60079-0 & EN 60079-1.

ExnC & ExtD SWITCHES (Cert: HNL07ATEX0001X)

Enclosures are certified ExnC IIC T4/T5/T6 & ExtD A22 IP66 100°C to EN 60079-0, EN60079-15, EN 61241-0 & EN 61241-1.

Exia SWITCHES (Cert: Baseefa06ATEX0231X)

Enclosures are certified Exia IIC T5/T6 to EN 60079-0 & EN 50020.

I.S. COMPATIBLE

Series 700 switches are classified as simple apparatus, allowing use in an I.S. circuit without individual certification.

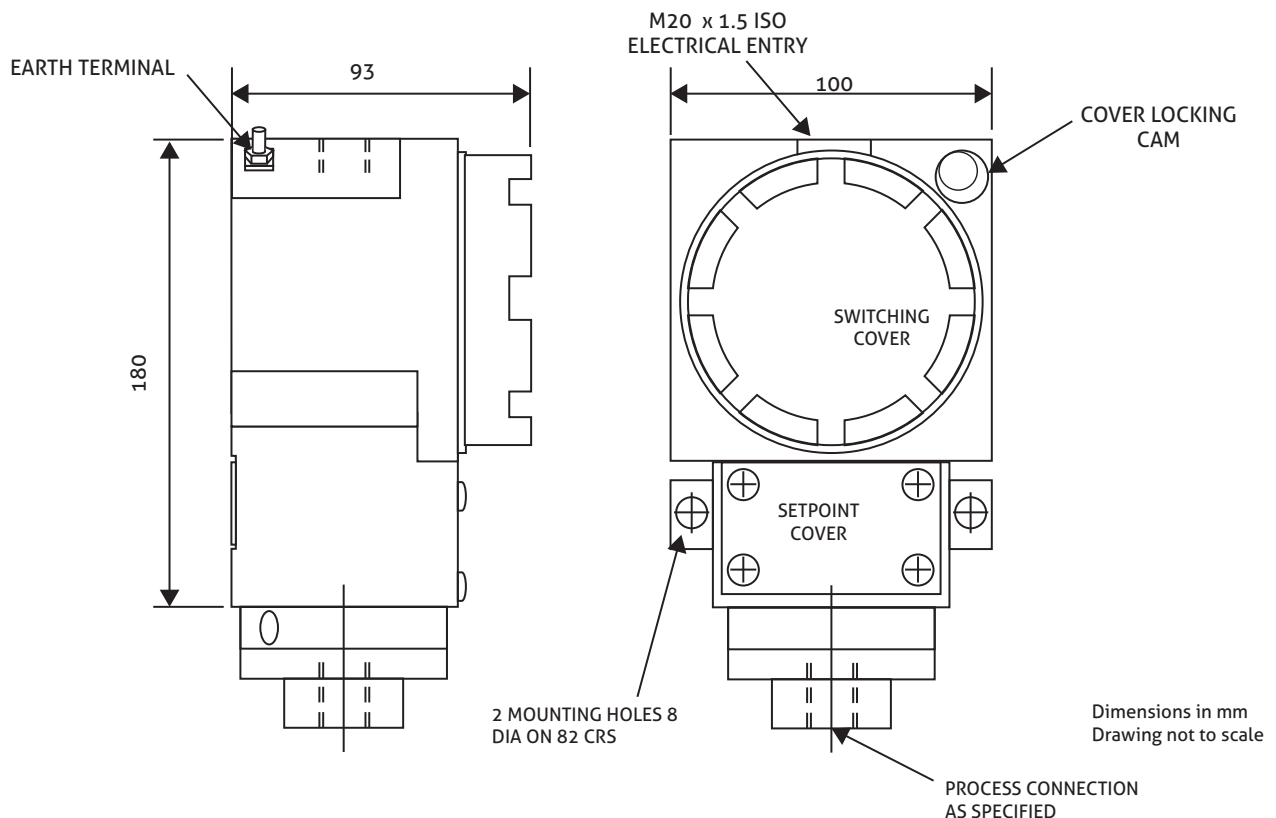

## Pressure Ranges

Set Point Ranges (bar)				Diaphragm Material			Chamber Proof Rating (bar)			Typical Dimensions (centreline vertical) H x W x D	
Range Code	MIN	MAX	Units	% RESET	Code 1	Code 2	Code 7	Anodised Aluminium Code 1	316 St. Steel Code 5	Hastelloy C Code 7	
<b>714 PZ</b> <b>715 PZ</b>	-8 -15	8 15	mBar	2	✓ ✓	✓ ✓	✗ ✗	✗ ✗	0.5 0.5	✗ ✗	250 x 300 x 316
<b>724 PZ</b> <b>725 PZ</b>	-25 -50	25 50	mBar	2	✓ ✓	✓ ✓	✓ ✓	2 2	2 2	● ●	227 x 185 x 195
<b>734 PZ</b> <b>735 PZ</b> <b>736 PZ</b>	-125 -250 -500	125 250 500	mBar	2	✓ ✓ ✓	✓ ✓ ✓	✓ ✓ ✓	10 10 10	10 10 10	● ● ●	220 x 108 x 122
<b>744 PZ</b> <b>745 PZ</b> <b>746 PZ</b>	-0.6 -1 -1	0.6 1.4 6.0	mBar	2	✓ ✓ ✓	✓ ✓ ✓	✓ ✓ ✓	30 30 30	30 30 30	● ● ●	195 x 100 x 93
<b>734 P</b> <b>735 P</b> <b>736 P</b> <b>737 P</b>	25 50 100 300	250 500 1200 3500	mBar	2	✓ ✓ ✓ ✓	✓ ✓ ✓ ✓	✓ ✓ ✓ ✓	10 10 10 10	10 10 10 10	● ● ● ●	220 x 108 x 122
<b>744 P</b> <b>745 P</b> <b>746 P</b> <b>748 P</b> <b>747 P</b>	0.1 0.2 0.7 1 2	1.4 3.0 7.0 10 21	bar	2	✓ ✓ ✓ ✓ ✓	✓ ✓ ✓ ✓ ✓	✓ ✓ ✓ ✓ ✓	30 30 30 30 35	30 30 30 30 35	30 30 30 30 35	180 x 100 x 93
<b>754 P</b> <b>755 P</b> <b>756 P</b> <b>757 P</b> <b>758 P</b>	1.2 3 7 20 60	12 30 70 210 600	bar	3	✗ ✗ ✗ ✗ ✗	✓ ✓ ✓ ✓ ✓	✓ ✓ ✓ ✓ ✓	✗ ✗ ✗ ✗ ✗	250 250 250 350 1000	250 250 250 350 1000	190 x 100 x 93
<b>Differential Pressure Ranges</b>											
<b>714 DPZ</b> <b>715 DPZ</b>	-8 -15	8 15	mBar	2.5	✓ ✓	✓ ✓	✗ ✗	✗ ✗	0.5 0.5	✗ ✗	260 x 300 x 316
<b>724 DPZ</b> <b>725 DPZ</b>	-25 -50	25 50	mBar	2.5	✓ ✓	✓ ✓	✓ ✓	2 2	2 2	● ●	263 x 185 x 195
<b>734 DPZ</b> <b>735 DPZ</b>	-125 -250	125 250	mBar	2.5	✓ ✓	✓ ✓	✓ ✓	10 10	10 10	✗ ✗	265 x 108 x 122
<b>734 DPZM</b> <b>735 DPZM</b> <b>736 DPZM</b>	-100 -200 -400	100 200 400	mBar	3	✗ ✗ ✗	✗ ✗ ✗	✓ ✓ ✓	✗ ✗ ✗	300 300 300	✗ ✗ ✗	284 x 104 x 122
<b>744 DPZ</b> <b>745 DPZ</b>	-0.9 -1	0.9 2	bar	3	✓ ✓	✓ ✓	✓ ✓	✗ ✗	30 30	✗ ✗	233 x 100 x 93
<b>734 DP</b> <b>735 DP</b> <b>736 DP</b> <b>737 DP</b>	25 50 100 300	250 500 1200 3500	mBar	2.5	✓ ✓ ✓ ✓	✓ ✓ ✓ ✓	✓ ✓ ✓ ✓	10 10 10 10	10 10 10 10	● ● ● ●	265 x 108 x 122
<b>734 DPM</b> <b>735 DPM</b> <b>736 DPM</b> <b>737 DPM</b>	20 40 100 300	200 400 1000 3000	mBar	3	✗ ✗ ✗ ✗	✗ ✗ ✗ ✗	✓ ✓ ✓ ✓	✗ ✗ ✗ ✗	300 300 300 300	✗ ✗ ✗ ✗	284 x 104 x 122
<b>744 DP</b> <b>745 DP</b> <b>746 DP</b> <b>747 DP</b>	0.2 0.4 1 2	2 4 10 21	bar	2.5	✓ ✓ ✓ ✓	✓ ✓ ✓ ✓	✓ ✓ ✓ ✓	30 30 30 35	30 30 30 35	30 30 30 35	233 x 100 x 93
<b>746 DPM</b> <b>747 DPM</b> <b>748 DPM</b>	0.7 2 10	7 21 100	bar	3	✗ ✗ ✗	✗ ✗ ✗	✓ ✓ ✓	✗ ✗ ✗	300 300 300	✗ ✗ ✗	284 x 104 x 122

Key to options: ✓ = available ✗ = not available ● = check availability with Rotherm Technical Sales

Output Switch Codes				
Single Switch	Twin Switch 2 x SPDT	Output Switch Rating	Contact Material	Notes
01	-	250/480 Vac 10A, 28 Vdc 4A	Silver	Adjustable differential microswitch ( ≈ 5 to 12% of span)
13	23	250 Vac 4A, 28 Vdc 2A	Silver	Rototherm standard low differential microswitches
14	24	125 Vac 800mA, 28 Vdc 800mA	Gold	
15	25	125 Vac 800mA, 28 Vdc 800mA	Gold	Environment free encapsulated low differential microswitch
17	27	250 Vac 4A, 28 Vdc 2A	Silver	Environment free encapsulated low differential microswitch
1A	2A	250 Vac 6A, 28 Vdc 2.5A	Silver	Rototherm standard encapsulated microswitches
1B	2B	250 Vac 100mA, 28 Vdc 100mA	Gold	

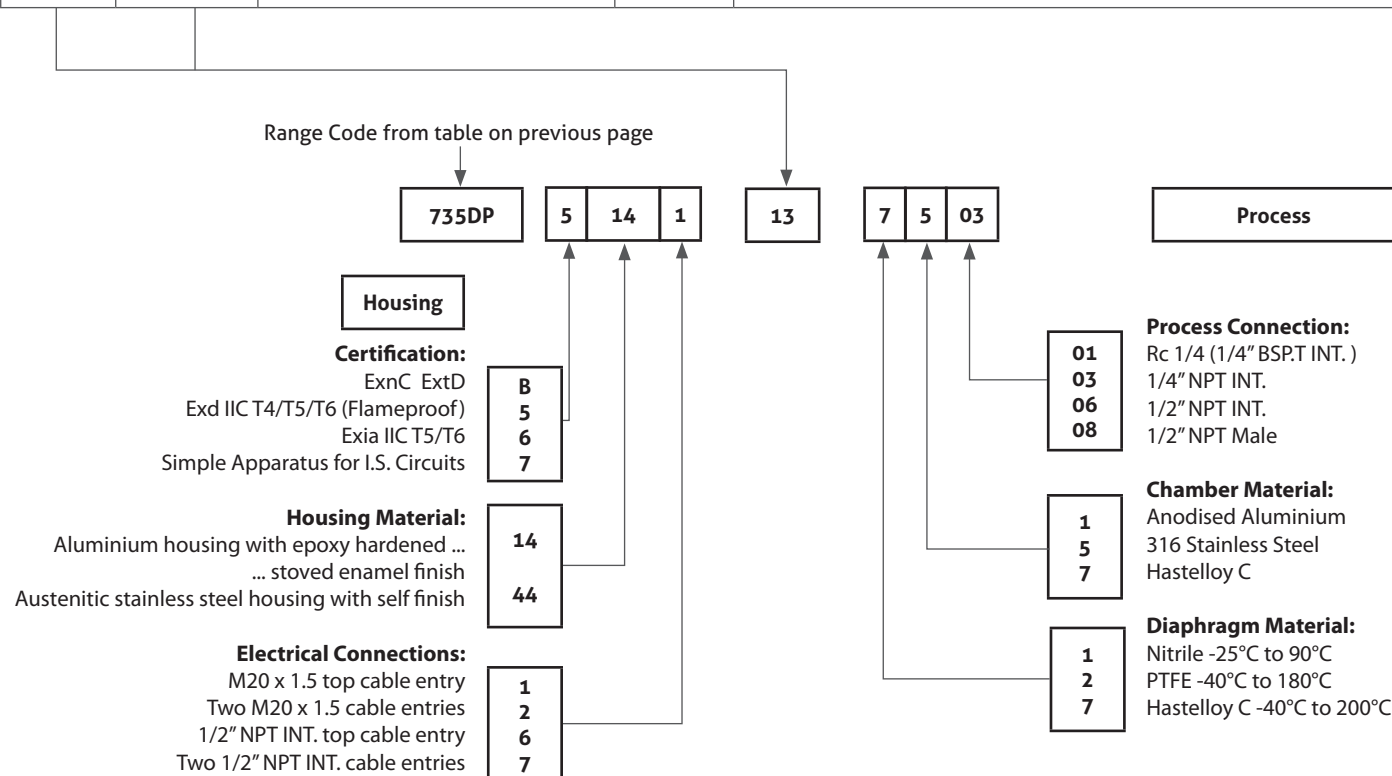

#### Notes on Output Switch Selection:

- Gold contact microswitches are especially well suited for low voltages and currents, or for applications with low switchin frequencies or sulphurous atmospheres. When heavier loads need to be switched preference should usually be given to silver contacts.
- The use of twin switches will increase the basic reset by 1%. The combined reset band must not exceed 7%.
- When twin switches are set up to operate as DPDT, simultaneous operation on both rising and falling pressures cannot be guaranteed due to mechanical variations between individual microswitches.
- The use of output switch codes 1A, 2A, 1B and 2B will increase the basic reset by 1%.
- Output switch code 01 cannot be used with an enclosure having two electrical entries.

#### Notes:

- Typical dimensions shown on range table are for a 1/4" internal connection and may increase for alternative connection sizes.
- Dust and weatherproof ratings are IP66 to BS EN 60529 (IE60529).
- An 'M' within the range code signifies DP connections suitable for direct mounting of standard equalising manifolds.
- On some ranges 1/2" NPT connections are via a supplied adaptor.
- A 'Z' within the range code signifies at or below zero. This is achieved with the use of a stainless steel biasing assembly within the process chamber. If stainless steel is not compatible with the process an alternative 'X' option is available (e.g. 744PX instead of 744PZ).
- A large number of flanged, chemical seal and alternative threaded connections are available as special options. Please contact Rototherm Technical Sales for details.

### Scale Accuracy & Setpoint Calibration:

A 0-100 scale is fitted to all switches and provides an approximate indication of the setpoint relative to the range of the switch. The scale is not intended for precise calibration purposes. For precise calibration the scale should be used for initial guidance and the final adjustment made against an instrument sufficiently accurate to meet the site requirements.

**Combined Switching Errors & Maximum Working Pressure (MWP):**  
In accordance with BS6134 1991:

The sum of the average switching errors and the operating value repeatability will typically not exceed 0.3% of range span, at setpoints of 10%, 50% and 90% of span, at constant calibration and measurement temperatures.

The maximum working pressure of the Series 700 switches is 0.67 x the proof pressure. It should be noted that diaphragm type switches generally have a high overload capability.

### Reset (Switching Differential):

The reset varies throughout the range, normally increasing with setpoint, and the figure quoted in the range table is the switching differential value (as defined in BS6134) expressed as a percentage of the span at the mid range setpoint.

### Ambient Temperature Ratings:

Enclosures are rated for continuous use over the temperature range -20°C to +85°C. The use of a high T class will reduce the maximum ambient temperature. At T6 the maximum ambient temperature is 40°C for Exd, 65°C for ExnC and 75°C for Exia.

Storage limits for all enclosures are -50°C to +90°C.

Exposure of the enclosure to direct sunlight should be such that the heat gain due to absorption of radiant energy does not cause the enclosure temperature to exceed the recommended maximum. Sufficient signal line cooling must always be provided to ensure that heat conduction from the process will not cause the switch enclosure to operate outside the stated ambient temperature limits.

### Temperature Coefficient:

The additional error, relative to a setpoint calibration of 20°C, will not exceed 0.3% per 10°C change within the normal ambient temperature range of the switch enclosure.

### Process Options:

For switches fitted with metallic diaphragms, a PTFE ring is incorporated on some ranges to provide additional sealing. Should PTFE not be compatible with the process media please contact Rototherm Technical Sales for advice on alternatives.

### Standards

This product complies with standard EN60947-5-1:2004 in addition to the standards listed for hazardous area certification.

### Specifications

Parameter definitions are in accordance with BS6134:1991 (Pressure and Vacuum Switches).

