

Proximity Sensors Inductive Nickel-Plated Brass Housing Types IA, M12, M18 and M30



- Sensing distance: 2 to 15 mm
- Flush and non-flush types
- Long and short body
- Rated operational voltage: 10 - 40 VDC
- Output: DC 200 mA, NPN or PNP
- Make and break switching function
- LED-indication
- Protection: reverse polarity, short circuit, transients
- Cable and plug versions

Product Description

A family of inexpensive general purpose inductive proximity switches in industrial standard nickel-plated brass housings. M12, M18 and M30 types. They are able to handle simple applications

where a basic sensor provides adequate sensing performance. Output are open collector NPN or PNP transistors. Available with cable and M12 plug.

Ordering Key

IA12ASF02NOM1

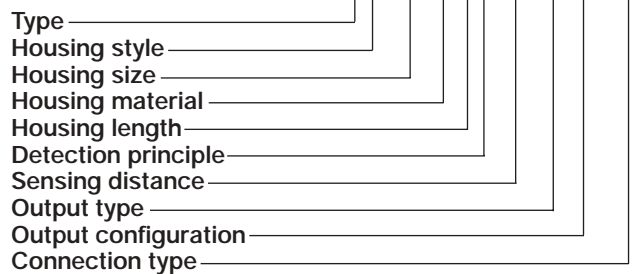

Type Selection

| Housing diameter | Connec- tion | Body style | Rated operating distance S_n | Ordering no. NPN Make switching | Ordering no. PNP Make switching | Ordering no. NPN Break switching | Ordering no. PNP Break switching |
|------------------|-----------------|---------------|--------------------------------------|---------------------------------------|---------------------------------------|--|--|
| M12 | Cable | Short | 2 mm ¹⁾ | IA 12 DSF 02 NO | IA 12 DSF 02 PO | | |
| M12 | Plug | Short | 2 mm ¹⁾ | IA 12 ASF 02 NOM1 | IA 12 ASF 02 POM1 | | |
| M12 | Cable | Long | 2 mm ¹⁾ | IA 12 DLF 02 NO | IA 12 DLF 02 PO | | |
| M12 | Plug | Long | 2 mm ¹⁾ | IA 12 ALF 02 NOM1 | IA 12 ALF 02 POM1 | | |
| M12 | Cable | Short | 4 mm ²⁾ | IA 12 DSN 04 NO | IA 12 DSN 04 PO | IA 12 DSN 04 NC | IA 12 DSN 04 PC |
| M12 | Plug | Short | 4 mm ²⁾ | IA 12 ASN 04 NOM1 | IA 12 ASN 04 POM1 | IA 12 ASN 04 NCM1 | IA 12 ASN 04 PCM1 |
| M18 | Cable | Short | 5 mm ¹⁾ | IA 18 DSF 05 NO | IA 18 DSF 05 PO | | |
| M18 | Plug | Short | 5 mm ¹⁾ | IA 18 ASF 05 NOM1 | IA 18 ASF 05 POM1 | | |
| M18 | Cable | Long | 5 mm ¹⁾ | | IA 18 DLF 05 PO | | IA 18 DLF 05 PC |
| M18 | Plug | Long | 5 mm ¹⁾ | | IA 18 ALF 05 POM1 | | IA 18 ALF 05 PCM1 |
| M18 | Cable | Short | 8 mm ²⁾ | IA 18 DSN 08 NO | IA 18 DSN 08 PO | IA 18 DSN 08 NC | IA 18 DSN 08 PC |
| M18 | Plug | Short | 8 mm ²⁾ | IA 18 ASN 08 NOM1 | IA 18 ASN 08 POM1 | IA 18 ASN 08 NCM1 | IA 18 ASN 08 PCM1 |
| M30 | Cable | Short | 10 mm ¹⁾ | IA 30 DSF 10 NO | IA 30 DSF 10 PO | | |
| M30 | Plug | Short | 10 mm ¹⁾ | IA 30 ASF 10 NOM1 | IA 30 ASF 10 POM1 | | |
| M30 | Cable | Long | 10 mm ¹⁾ | | IA 30 DLF 10 PO | | IA 30 DLF 10 PC |
| M30 | Plug | Long | 10 mm ¹⁾ | | IA 30 ALF 10 POM1 | | |
| M30 | Cable | Short | 15 mm ²⁾ | IA 30 DSN 15 NO | IA 30 DSN 15 PO | | |
| M30 | Plug | Short | 15 mm ²⁾ | IA 30 ASN 15 NOM1 | IA 30 ASN 15 POM1 | | |

¹⁾ For flush mounting in metal

²⁾ For non-flush mounting in metal



Specifications

| | | | |
|--|--|-------------------------------------|--|
| Rated operational voltage (U _B) | 10 to 40 VDC (ripple incl.) | Ambient temperature | |
| Ripple | ≤ 10% | Operating | -25° to +70°C (-13° to +158°F) |
| Output current (I _o) | ≤ 200 mA @ 50°C (≤ 150 mA @ 50-70°C) | Storage | -30° to +80°C (-22° to +176°F) |
| No load supply current (I _o) | IA 12 ≤ 10 mA IA 18 ≤ 10 mA IA 30 ≤ 10 mA | Housing material | |
| Voltage drop (U _d) | Max. 2.5 VDC @ 200 mA | Body | Nickel-plated brass |
| Protection | Reverse polarity, short-circuit, transients | Front | Grey thermoplastic polyester |
| Transient voltage | 1 kV/0.5 J | Backpart | |
| Power ON delay (t _v) | 50 ms | Plug | NPB |
| Operating frequency (f) | IA12 ..F 02 ≤ 2000 Hz IA12 DSN 04 ≤ 2000 Hz IA18 ..F 05 ≤ 1500 Hz IA18 DSN 08 ≤ 1500 Hz IA30 ..F 10 ≤ 700 Hz IA30 DSN 15 ≤ 700 Hz | Cable | PBTP (black polyester) |
| Indication for output ON | LED, yellow | Nuts | NPB |
| Assured operating sensing distance (S _a) | 0 ≤ S _a ≤ 0.81 x S _n | Connection | |
| Effective operating distance (S _r) | 0.9 x S _n ≤ S _r ≤ 1.1 x S _n | Cable | 2 m, 3 x 0.3 mm ² , grey PVC, oil proof M12 x 1 |
| Usable operating distance (S _u) | 0.9 x S _r ≤ S _u ≤ 1.1 x S _r | Plug | CONH1A/CONH1O series |
| Repeat accuracy (R) | ≤ 5% | Cables for plug (-1) | |
| Differential travel (H) (Hysteresis) | 1 to 15% of sensing dist. | Degree of protection | IP 67 |
| | | Weight (cable/nuts included) | IA 12 .S. 100 g IA 12 .L. 105 g IA 18 .S. 120 g IA 18 .L. 130 g IA 30 .S. 185 g IA 30 .L. 195 g |
| | | Tightening torque | IA 12 7.0 Nm (x) 15.0 Nm (y) IA 18 27.5 Nm IA 30 50.0 Nm |
| | | Approvals | UL, CSA |
| | | CE-marking | Yes |

Dimensions

| Type | A | B Ø mm | C mm | D mm | E mm | F mm | SW mm |
|--------------------|----------------|-----------|---------|---------|---------|---------|----------|
| IA 12 DSF 02 .O | M12 x 1 x 30 | 10.7 | 30 | 11 | 5.0 | 4 | 17 |
| IA 12 ASF 02 .O M1 | M12 x 1 x 30 | 10.7 | 30 | 25.2 | | 4 | 17 |
| IA 12 DLF 02 .O | M12 x 1 x 50 | 10.7 | 50 | 11 | 5.0 | 4 | 17 |
| IA 12 ALF 02 .O M1 | M12 x 1 x 50 | 10.7 | 50 | 25.2 | | 4 | 17 |
| IA 12 DSN 04 .O | M12 x 1 x 30 | 10.7 | 34 | 11 | 5.0 | 4 | 17 |
| IA 12 ASN 04 .O M1 | M12 x 1 x 30 | 10.7 | 34 | 25.2 | | 4 | 17 |
| IA 18 DSF 05 .O | M18 x 1 x 30 | 16.7 | 30 | 11.6 | 15.4 | 4 | 24 |
| IA 18 ASF 05 .O M1 | M18 x 1 x 30 | 16.7 | 30 | 25.0 | | 4 | 24 |
| IA 18 DLF 05 .. | M18 x 1 x 50 | 16.7 | 50 | 11.6 | 15.4 | 4 | 24 |
| IA 18 ALF 05 .O M1 | M18 x 1 x 50 | 16.7 | 50 | 25.0 | | 4 | 24 |
| IA 18 DSN 08 .O | M18 x 1 x 30 | 16.7 | 38 | 11.6 | 15.4 | 4 | 24 |
| IA 18 ASN 08 .O M1 | M18 x 1 x 30 | 16.7 | 38 | 25.0 | | 4 | 24 |
| IA 30 DSF 10 .O | M30 x 1.5 x 30 | 28 | 30 | 13.6 | 15.4 | 5 | 36 |
| IA 30 ASF 10 .O M1 | M30 x 1.5 x 30 | 28 | 30 | 25.0 | | 5 | 36 |
| IA 30 DLF 10 .. | M30 x 1.5 x 50 | 28 | 50 | 13.6 | 15.4 | 5 | 36 |
| IA 30 ALF 10 .O M1 | M30 x 1.5 x 50 | 28 | 50 | 25.0 | | 5 | 36 |
| IA 30 DSN 15 .O | M30 x 1.5 x 30 | 28 | 42 | 13.6 | 15.4 | 5 | 36 |
| IA 30 ASN 15 .O M1 | M30 x 1.5 x 30 | 28 | 42 | 25.0 | | 5 | 36 |

Dimensions (cont.)

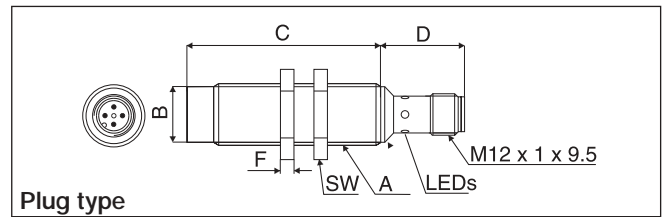
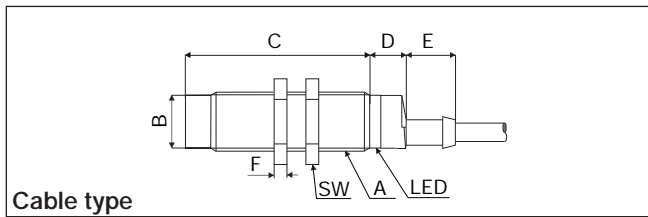

Wiring Diagrams

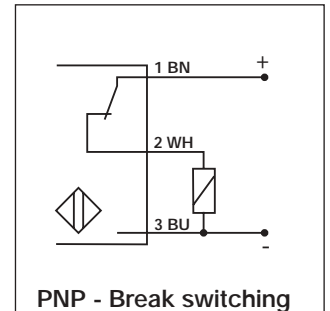
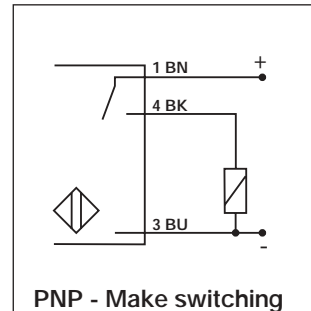
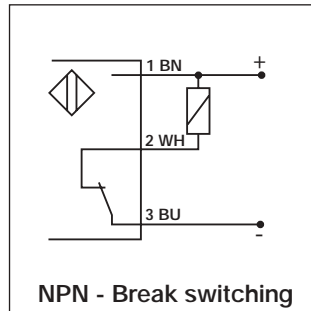
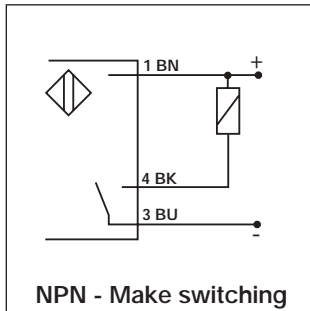

Installation Hints

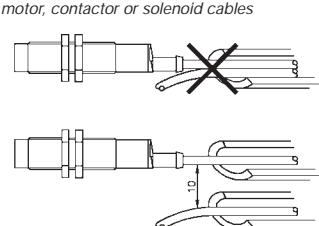
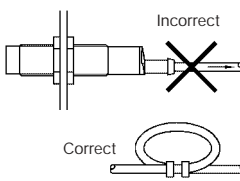
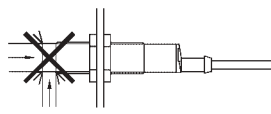
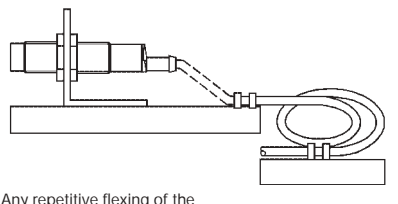
| | | | |
|---|---|--|--|
| <p>To avoid interference from inductive voltage/current peaks, separate the prox. switch power cables from any other power cables, e.g. motor, contactor or solenoid cables</p>  | <p>Relief of cable strain</p>  <p>The cable should not be pulled</p> | <p>Protection of the sensing face</p>  <p>A proximity switch should not serve as mechanical stop</p> | <p>Switch mounted on mobile carrier</p>  <p>Any repetitive flexing of the cable should be avoided</p> |
|---|---|--|--|

Delivery Contents

- Inductive proximity switch IA..
- 2 nuts NPB
- Packaging: plastic bag

Accessories

M12 connector

- | | |
|-----------|-----------------------|
| CONH10-A2 | (90°, 2 m cable) |
| CONH10-A5 | (90°, 5 m cable) |
| CONH10-S2 | (straight, 2 m cable) |
| CONH10-S5 | (straight, 5 m cable) |



Detection Diagrams

