

ASZxx.7xx / ASZxx.8xx

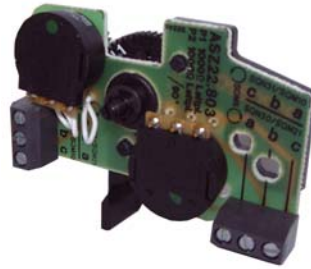

ASZxx.7xx / ASZxx.8xx
ASZxx.9xx



ASZxx.3x



ASZxx.3x

Potentiometers

ASZ...

For integration into SQM... and SQN... actuators to indicate the position of the actuator's drive shaft.

Single and double potentiometers in wire or conductive plastic design.

The ASZ... and this Data Sheet are intended for use by OEMs which integrate the potentiometers in their products.

Use

The ASZ... potentiometers are designed for fitting to the drive shafts of actuators type SQM... and SQN....

They can be used for both position indication and position feedback (position checkback signal).

The wire potentiometers are suited for general use.

For actuators in combination with electronic fuel / air ratio control systems or SQM5... actuators together with AGA56... electronic function modules, conductive plastic potentiometers are mandatory (extended life and better resolution).

Warning notes



To avoid injury to persons, damage to property or the environment, the following warning notes must be observed.

Do not interfere with or modify the potentiometers!

- All activities (mounting, installation and service work, etc.) must be performed by qualified staff
- Before making any wiring changes in the connection area, completely isolate the plant from mains supply (all-polar disconnection). Ensure that the plant cannot be inadvertently switched on again and that it is indeed dead. If not observed, there is a risk of electric shock hazard
- Ensure protection against electric shock hazard by providing adequate protection for the connection terminals
- Each time work has been carried out (mounting, installation, service work, etc.), check to ensure that wiring is in an orderly state
- After fall or shock, the potentiometers must not be put into operation because safety functions can be adversely affected, even if the potentiometers do not exhibit any damage

Planning notes

Connection diagram

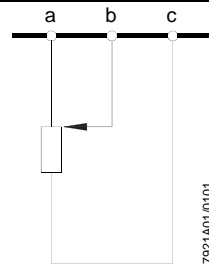

Potentiometer shown in start position

Terminal markings:

a = pickup at end of potentiometer

b = potentiometer wiper

c = pickup at end of potentiometer

Apply operating voltage to «a» and «c».

Conductive plastic potentiometers can be destroyed if operating voltage is applied to «a → b» or «b → c».

Mounting notes

Ensure that the relevant national safety regulations are complied with.

Standards and certificates



Note!
Only in connection with actuators!



EAC Conformity mark (Eurasian Conformity mark)



ISO 9001:2008

ISO 14001:2004

OHSAS 18001:2007

Disposal notes



The potentiometers contain electrical and electronic components and must not be disposed of together with domestic waste.

Ensure that local and currently valid legislation is observed.

Mechanical design

The potentiometers consist of a wire or conductive plastic resistance track and are accommodated in a dust-proof plastic casing on a printed circuit board. The electrical connections are made via triple-pole screw terminal strips. The potentiometers have no mechanical limitation of the angular rotation.

The movement from the actuator's drive shaft to the potentiometer's spindle is transferred as follows:

- With ASZxx.7xx and ASZxx.8xx:
 - Rigid, by means of a clamp sitting directly on the drive shaft
 - With almost no mechanical and hysteresis via plastic gearwheels
- With ASZxx.3x:
 - Rigid, by means of a clamp sitting directly on the drive shaft

Type summary

Material	Angular rotation	Resistance	For actuators		
			SQM1..., SQM2..., SQM5...	SQN3... ²⁾ , SQN4..., SQN9... ³⁾	SQN7... ⁴⁾ , SQM1..., SQM2... ⁵⁾ , SQM5...
Single potentiometers					
Wire	90°	135 Ω	ASZ16.703	ASZ16.703	---
		220 Ω	ASZ8.703	ASZ8.703	---
		1000 Ω	ASZ12.703	ASZ12.703	---
	135°	135 Ω	ASZ16.733 ¹⁾	ASZ16.733 ¹⁾	---
		220 Ω	ASZ8.733	ASZ8.733	---
		1000 Ω	ASZ12.733	ASZ12.733	---
Conductive plastic	90°	1000 Ω	ASZ12.803	ASZ12.803	ASZ12.30
	135°	1000 Ω	ASZ12.833	ASZ12.833	ASZ12.33
Double potentiometers					
Wire	90°	1000 / 1000 Ω	ASZ22.703	ASZ22.703	---
		135 / 135 Ω	ASZ66.703	ASZ66.703	---
		1000 / 550 Ω	ASZ72.703	ASZ72.703	---
		220 / 220 Ω	ASZ88.733 ¹⁾	ASZ88.733 ¹⁾	---
		1000 / 220 Ω	ASZ82.733 ¹⁾	ASZ82.733 ¹⁾	---
		1000 / 1000 Ω	ASZ22.733	ASZ22.733	---
Conductive plastic	90°	1000 / 1000 Ω	ASZ22.803	ASZ22.803	ASZ22.30
	135°	1000 / 1000 Ω	ASZ22.833	ASZ22.833	ASZ22.33
Wire / conductive plastic	90°	1000 / 1000 Ω	ASZ22.903	ASZ22.903	---
	135°	1000 / 1000 Ω	ASZ22.933	ASZ22.933	---

¹⁾ Only available on request

²⁾ Only with high cover (refer to Data Sheet 7808 and «Ordering»)

³⁾ Only with additional AGA09 potentiometer fixing (refer to «Ordering»)

⁴⁾ Version with high cover (refer to Data Sheet N7804):

SQN70... / SQN71...: Connection diagrams no. 0, 6, 7

SQN74... / SQN75...: Connection diagrams no. 6, 7, 8, 9, K

⁵⁾ Not at units with external position indication

Potentiometers ASZ...

refer to «Type summary»

- ASZxx.3x refer to Mounting Instructions M7921 (4 319 9604 0)
- ASZxx.7xx refer to Mounting Instructions M7806 / M7808 / M7812 (4 319 2263 0)
- ASZxx.8xx refer to Mounting Instructions M7806 / M7808 / M7812 (4 319 2263 0)
- ASZxx.9xx refer to Mounting Instructions M7806 / M7808 / M7812 (4 319 2263 0)



Conversion kit

AGA32

- For retrofitting ASZ...7... or ASZ...8... potentiometers to SQN3... / SQN4... (conversion from low to high housing cover)



Cover

AGA34

- For retrofitting ASZxx.3x potentiometers to SQN70... / SQN71... actuators

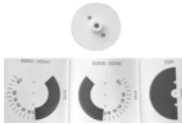

Service kit

AGA33

(only for ASZxx.7xx and ASZxx.8xx)

- For use with SQM... / SQN...
- For replacement of potentiometer old / new in case of failure or replacement of former potentiometer



Potentiometer fixing

AGA09

(only for ASZxx.7xx and ASZxx.8xx)

- For use with SQN9...

Technical data

General unit data	Type of potentiometer	ASZxx.7xx ASZxx.8xx	ASZxx.3x
	Operating voltage	DC 10 V	DC 10 V
	Permissible hysteresis	0.2 % of 90° or 135°	0.3 % of 90° or 135°
	Total resistance tolerance	±20 %	±20 %
	Mechanical angular rotation	360°, with no limit stops	360°, with no limit stops
	Effective angular rotation	90° or 135°	90° or 135°
	Total resistance (Rges) at		
	- <0°	Infinite	Infinite
	- >90° or >135°	Infinite	Infinite
	Terminal strip	Triple-pole	Triple-pole
	For cross-sectional areas of	0.5...1 mm ²	0.5...1 mm ²
	Adjusting torque of potentiometer	≤0.025 Nm	≤0.04 Nm
	Mounting position	Optional	Optional
	Weight		
	- Single potentiometer	Approx. 27 g	Approx. 15 g
	- Double potentiometer	Approx. 41 g	Approx. 20 g
Environmental conditions	Storage	DIN EN 60721-3-1	DIN EN 60721-3-1
	Climatic conditions	Class 1K3	Class 1K3
	Mechanical conditions	Class 1M2	Class 1M2
	Temperature range	-20...+60 °C	-20...+60 °C
	Humidity	<95 % r.h.	<95 % r.h.
	Transport	DIN EN 60721-3-2	DIN EN 60721-3-2
	Climatic conditions	Class 2K2	Class 2K3
	Mechanical conditions	Class 2M2	Class 2M2
	Temperature range	-50...+75 °C	-50...+75 °C
	Humidity	<95 % r.h.	<95 % r.h.
	Operation	DIN EN 60721-3-3	DIN EN 60721-3-3
	Climatic conditions	Class 3K3	Class 3K3
	Mechanical conditions	Class 3M3	Class 3M3
	Temperature range	-20...+70 °C	-20...+70 °C
	Humidity	<95 % r.h.	<95 % r.h.
	 Condensation, formation of ice and ingress of water are not permitted!		
Wire potentiometers	Load	Max. 1 W at 70 °C	---
	Wiper current rating	Min. 1 mA Max. 100 mA	---
	Transfer resistance (Rü) of wiper contact	Rü ≤2 % of Rges at 1 mA	---
	Life cycle	Approx. 250,000 switching cycles	---
Conductive plastic potentiometer	Wiper current rating	Max. 100 µA	Max. 100 µA
	Transfer resistance of wiper contact	Max. Rü ≤100 Ω	Max. Rü ≤500 Ω
	Linearity (referred to Rges = 1000 Ω)	±1 %	±1 %
	Smoothness (alpha = 10°) / microlinearity	<0.1 %	±0.5 %
	Life cycle	Approx. 2 million switching cycles	Approx. 2 million switching cycles

Dimensions

Dimensions in mm

ASZxx.3x

Broken lines →
Double potentiometer

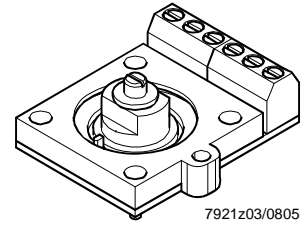
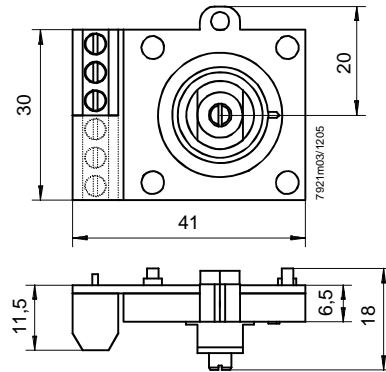

ASZxx.3x

Broken lines →
Double potentiometer

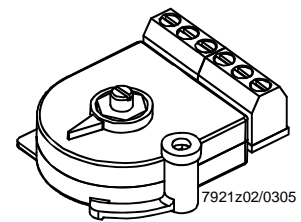
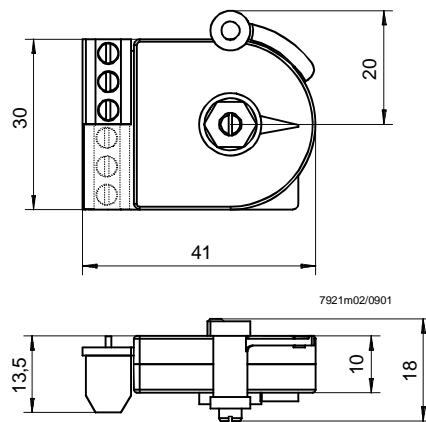

ASZxx.7xx / ASZxx.8xx ASZxx.9xx

